

CNC Werkzeughalter

BILZ

Member of the LEITZ Group

Tool Holder

www.bilz.de





Liebe Leserin, lieber Leser,

an der „Schneide“ wird bekanntlich das Geld verdient. Dabei beeinflusst die Produktivität dieser Schneide die Gesamtkosten von Zerspanungsprozessen, zu denen sie selbst nur zwischen 4 – 6 % beiträgt. Diesen Aussagen werden wohl die Mehrzahl aller Produktions und Zerspanungsfachleute zustimmen.

Doch was unternehmen Sie, um die Leistungsfähigkeit der Schneide voll auszunutzen und deren Standwege zu erhöhen?

Das vorliegende Handbuch soll Sie bei der Auswahl von optimalen Spannmitteln für Ihre „Schneiden“ unterstützen.

Unsere lange Erfahrung als traditionsreiches Familienunternehmen hilft uns dabei, Produkte zu entwickeln, denen Sie vertrauen können, und in diesem Handbuch ein umfassendes Produktspektrum für Sie zusammenzustellen.

Dabei sind zahlreiche Verbesserungen eingeflossen. „Immer besser“ ist für uns kein Schlagwort. Es ist ein Qualitätsversprechen.

Und unsere Produkte und wir selbst halten, was wir versprechen.

Über das dargestellte Programm hinaus können wir Ihnen unterschiedlichste anwendungs-spezifische Lösungen anbieten.

Sprechen Sie uns auch für neue Lösungen gerne an.

Viele denken nach, wir denken gerne vor.

Im Namen des ganzen Bilz Teams

Dear Reader,

As everyone knows, money is made at the “cutting edge”. The productivity of this cutting edge influences the total costs of cutting processes, whereas its share amounts to 4 – 6 % only.

Most production and cutting experts will agree with these statements.

What do you undertake to fully profit from the performance of the cutting edge and to increase its tool life?

This manual will support you in selecting the optimal clamping tools for your “cutting edges”.

Our long experience as a traditional family-run company helps us to develop products you can rely on and to compile a comprehensive product range in this manual. Many improvements have been included.

“Always better” is not just a slogan for us. It is a promise for quality. And we and our products keep our promises. Beyond this product range we can offer you various custom-designed solutions.

Please talk to us about new solutions for your applications.

Many people react, we act.

On behalf of the whole Bilz Team

- A JIS B 6339 / MAS 403 BT / ISO7388-2 (BT)
Werkzeugaufnahmen
JIS B 6339 / MAS 403 BT / ISO7388-2 (BT) Tool holders
-
- Steilkegel mit Plananlage (FBT)
Face contact holders (FBT)
-
- B DIN 69871 / ISO7388-1 (SK) Werkzeugaufnahmen
DIN 69871 / ISO7388-1 (SK) Tool holders
-
- C DIN 69893(HSK-A) Werkzeugaufnahmen
DIN 69893 (HSK-A) Tool holders
-
- DIN 69893(HSK-E) Werkzeugaufnahmen
DIN 69893 (HSK-E) Tool holders
-
- D Zubehör
Accessories
-
- E Ersatzteile
Spare parts
-
- F Technische Spezifikationen
Technical details

Spannzangenfutter ER Collet chuck ER	A2 - A3
Super collet Spannzangenfutter Super collet chuck	A4 - A5
Fräseraufnahmen (Weldon / Whistle Notch) End mill holder (Weldon / Whistle Notch)	A6 - A9
Hochleistungsfräterspannfutter Hi-power milling chuck	A10
Schlanke Hochleistungsfräterspannfutter Slim Hi-power milling chuck	A11
Hydrodehnspannfutter Hydraulic expansion chuck	A12
NC Bohrfutter NC Drill chuck	A13
Aufnahmen für Morse-Kegel Morse taper holder	A13 - A14
Aufnahmen für Einschraubfräser Chuck for threaded milling heads	A15
Kombi-Aufsteckfräserdorn Combi shell mill holder	A16
Aufsteckfräserdorn Shell mill holder	A17
Reduzierhülsen Reduction Sleeves	A18
Bohrstangenrohlinge Boring bar blanks	A18
Kontrolldorn Test Arbor	A19
Spannzangenfutter Typ ERC Collet chuck Type ERC	A20 - A21
Steilkegel mit Plananlage (FBT) Face Contact Holders (FBT)	A22

Spannzangenfutter Typ ER für Spannzangen ISO 15488 (DIN 6499)
Collet chuck Type ER for collets to ISO 15488 (DIN 6499)

BT MAS 403
ISO7388-2

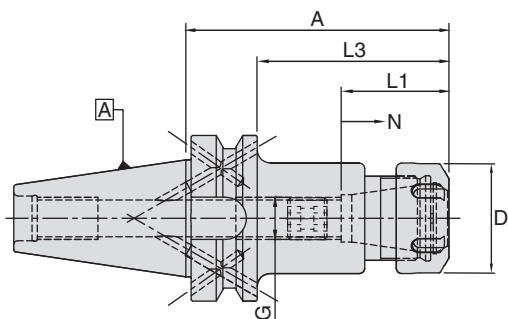

BT 30

Spannzange Collet Type	Bereich Range	D (mm)	A (mm)	L1 (mm)	L3 (mm)	G (mm)	N	Kühlmittelezufuhr Coolant supply	N/W (Kg)	Bezeichnung Designation	Ident No.
ER 16	1-10	28	70	32.5	48	M10	12	Form"AD"	0.7	WCCH/ER16-70/BT30	4600581
ER 20	1-13	34	70	38.0	48	M12	12	Form"AD"	0.9	WCCH/ER20-70/BT30	5065866
ER 25	2-16	42	70	41.0	48	M12	12	Form"AD"	0.6	WCCH/ER25-70/BT30	4600583
ER 32	2-20	50	70	47.0	48	M12	12	Form"AD"	0.8	WCCH/ER32-70/BT30	5044372
ER 16	1-10	28	100	32.5	78	M10	12	Form"AD"	0.7	WCCH/ER16-100/BT30	6733380
ER 20	1-13	34	100	38.0	78	M12	12	Form"AD"	1.3	WCCH/ER20-100/BT30	6733382
ER 25	2-16	42	100	41.0	78	M12	12	Form"AD"	0.6	WCCH/ER25-100/BT30	6733384

SK DIN 69871
ISO7388-1

BT 40

Spannzange Collet Type	Bereich Range	D (mm)	A (mm)	L1 (mm)	L3 (mm)	G (mm)	N	Kühlmittelezufuhr Coolant supply	N/W (Kg)	Bezeichnung Designation	Ident No.
ER 16	1-10	28	70	32.5	48	M10	12	Form"AD/B"	1.0	WCCH/ER16-70/BT40	6733387
ER 20	1-13	34	70	38.0	48	M12	12	Form"AD/B"	1.2	WCCH/ER20-70/BT40	6733390
ER 25	2-16	42	70	41.0	48	M16	12	Form"AD/B"	1.0	WCCH/ER25-70/BT40	6733393
ER 32	2-20	50	70	47.0	48	M22X1.5	12	Form"AD/B"	1.2	WCCH/ER32-70/BT40	6733396
ER 40	3-26	63	80	58.5	58	M22X1.5	12	Form"AD/B"	1.2	WCCH/ER40-80/BT40	6733399
ER 16	1-10	28	100	32.5	78	M10	12	Form"AD/B"	1.2	WCCH/ER16-100/BT40	6733388
ER 20	1-13	34	100	38.0	78	M12	12	Form"AD/B"	1.4	WCCH/ER20-100/BT40	6733391
ER 25	2-16	42	100	41.0	78	M16	12	Form"AD/B"	1.4	WCCH/ER25-100/BT40	6733394
ER 32	2-20	50	100	47.0	78	M22X1.5	12	Form"AD/B"	1.5	WCCH/ER32-100/BT40	6733397
ER 40	3-26	63	100	58.5	78	M22X1.5	12	Form"AD/B"	1.8	WCCH/ER40-100/BT40	6733400
ER 16	1-10	28	160	32.5	138	M10	12	Form"AD/B"	1.6	WCCH/ER16-160/BT40	5062757
ER 20	1-13	34	160	38.0	138	M12	12	Form"AD/B"	1.6	WCCH/ER20-160/BT40	5062758
ER 25	2-16	42	160	41.0	138	M16	12	Form"AD/B"	2.1	WCCH/ER25-160/BT40	5062759
ER 32	2-20	50	160	47.0	138	M22X1.5	12	Form"AD/B"	2.5	WCCH/ER32-160/BT40	5062760
ER 40	3-26	63	160	58.5	138	M22X1.5	12	Form"AD/B"	2.6	WCCH/ER40-160/BT40	5062761

HSK DIN 69893

Zubehör
Accessories

Ersatzteile und Zubehör / Spare Parts & Accessories: Pg.D7 Pg.D2 Pg.D4 Pg.D3

- Im Lieferumfang enthalten: mit Spannmutter (gewuchtet) und Verstelle schraube
- Höhere Wuchtgüte auf Anfrage
- Delivery includes: Clamping nut (balanced) & adjusting screw
- Higher balancing grade on request

Ersatzteile
Spare Parts

Technische Spezifikationen
Technical Details

Spannzangenfutter Typ ER für Spannzangen ISO 15488 (DIN 6499)

Collet chuck Type ER for collets to ISO 15488 (DIN 6499)

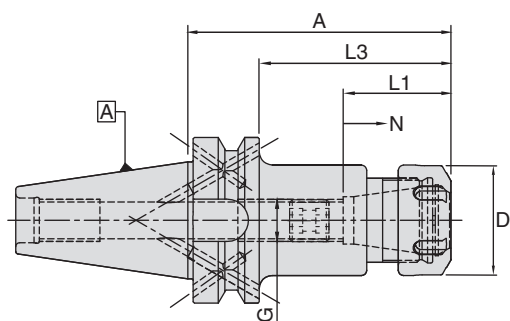

BT 50											
<div style="display: flex; justify-content: space-between; align-items: center;"> ≤ 3 μm G6.3 12000 RPM bar </div>											
Spannzange Collet Type	Bereich Range	D (mm)	A (mm)	L1 (mm)	L3 (mm)	G (mm)	N	Kühlmittelzufuhr Coolant supply	N/W (Kg)	Bezeichnung Designation	Ident No.
ER 20	1-13	34	70	38.0	48	M12	12	Form"AD/B"	4.0	WCCH/ER20-70/BT50	5062762
ER 25	2-16	42	70	41.0	48	M16	12	Form"AD/B"	3.4	WCCH/ER25-70/BT50	5062763
ER 32	2-20	50	70	47.0	48	M22X1.5	12	Form"AD/B"	3.5	WCCH/ER32-70/BT50	5062764
ER 40	3-26	63	80	58.5	58	M22X1.5	12	Form"AD/B"	3.6	WCCH/ER40-80/BT50	5062765
ER 16	1-10	28	100	32.5	78	M10	12	Form"AD/B"	3.6	WCCH/ER16-100/BT50	6733403
ER 20	1-13	34	100	38.0	78	M12	12	Form"AD/B"	4.0	WCCH/ER20-100/BT50	6733405
ER 25	2-16	42	100	41.0	78	M16	12	Form"AD/B"	3.8	WCCH/ER25-100/BT50	5062405
ER 32	2-20	50	100	47.0	78	M22X1.5	12	Form"AD/B"	3.9	WCCH/ER32-100/BT50	6733407
ER 40	3-26	63	100	58.5	78	M22X1.5	12	Form"AD/B"	3.8	WCCH/ER40-100/BT50	6733409
ER 16	1-10	28	160	32.5	138	M10	12	Form"AD/B"	4.1	WCCH/ER16-160/BT50	5062789
ER 20	1-13	34	160	38.0	138	M12	12	Form"AD/B"	4.1	WCCH/ER20-160/BT50	5062790
ER 25	2-16	42	160	41.0	138	M16	12	Form"AD/B"	4.1	WCCH/ER25-160/BT50	5062791
ER 32	2-20	50	160	47.0	138	M22X1.5	12	Form"AD/B"	4.6	WCCH/ER32-160/BT50	5062792
ER 40	3-26	63	160	58.5	138	M22X1.5	12	Form"AD/B"	4.6	WCCH/ER40-160/BT50	5062793

Ersatzteile und Zubehör / Spare Parts & Accessories:



- Im Lieferumfang enthalten: mit Spannmutter (gewuchtet) und Verstellerschraube
- Höhere Wuchtgüte auf Anfrage

- Delivery includes: Clamping nut (balanced) & adjusting screw
- Higher balancing grade on request

Super collet Spannzangenfutter
Super collet chuck

BT MAS 403
ISO7388-2

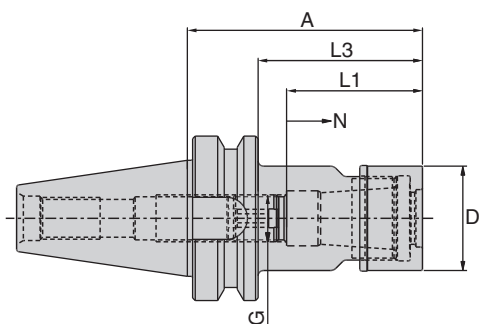

BT 30

Spannzange Collet Type	Bereich Range	D (mm)	A (mm)	L1 (mm)	L3 (mm)	G (mm)	N (mm)	Kühlmittelzufuhr Coolant supply	N/W (Kg)	Bezeichnung Designation	Ident No.
SC06	2-6	19.5	60	31.5	38	M8	12	Form "AD"	0,5	WSCH/SCF06-60/BT30	5100405
SC06	2-6	19.5	90	31.5	68	M8	12	Form "AD"	0,6	WSCH/SCF06-90/BT30	5100407
SC10	2-10	27.1	60	35.0	38	M12	12	Form "AD"	0,6	WSCH/SCF10-60/BT30	5100408
SC10	2-10	27.1	90	35.0	68	M12	12	Form "AD"	0,6	WSCH/SCF10-90/BT30	5100416
SC13	3-13	33.0	60	43.0	38	M15	16	Form "AD"	0,6	WSCH/SCF13-60/BT30	5100420
SC13	3-13	33.0	90	43.0	68	M15	16	Form "AD"	0,7	WSCH/SCF13-90/BT30	5100421
SC16	4-16	40.0	60	52.0	38	M18	16	Form "AD"	0,7	WSCH/SCF16-60/BT30	5100423
SC16	4-16	40.0	90	52.0	68	M18	16	Form "AD"	0,8	WSCH/SCF16-90/BT30	5100425
SC20	6-20	48.0	60	59.5	38	M22	16	Form "AD"	0,7	WSCH/SCF20-60/BT30	5100426
SC20	6-20	48.0	90	59.5	68	M22	16	Form "AD"	0,9	WSCH/SCF20-90/BT30	5100427
SC25	6-25	55.0	90	63.5	68	M28	20	Form "AD"	1,1	WSCH/SCF25-90/BT30	5100429

SK DIN 69871
ISO7388-1

HSK DIN 69893

BT 40

Spannzange Collet Type	Bereich Range	D (mm)	A (mm)	L1 (mm)	L3 (mm)	G (mm)	N (mm)	Kühlmittelzufuhr Coolant supply	N/W (Kg)	Bezeichnung Designation	Ident No.
SC06	2-6	19.5	90	31.5	63	M8	12	Form "AD"	1,1	WSCH/SCF06-90/BT40	5100431
SC06	2-6	19.5	120	31.5	93	M8	12	Form "AD"	1,2	WSCH/SCF06-120/BT40	5100434
SC06	2-6	19.5	150	31.5	123	M8	12	Form "AD"	1,3	WSCH/SCF06-150/BT40	5100435
SC10	2-10	27.1	90	35.0	63	M12	12	Form "AD"	1,2	WSCH/SCF10-90/BT40	5100436
SC10	2-10	27.1	120	35.0	93	M12	12	Form "AD"	1,3	WSCH/SCF10-120/BT40	5100437
SC10	2-10	27.1	150	35.0	123	M12	16	Form "AD"	1,4	WSCH/SCF10-150/BT40	5100439
SC13	3-13	33.0	90	43.0	63	M15	16	Form "AD"	1,3	WSCH/SCF13-90/BT40	5100441
SC13	3-13	33.0	120	43.0	93	M15	16	Form "AD"	1,5	WSCH/SCF13-120/BT40	5100442
SC13	3-13	33.0	150	43.0	123	M15	16	Form "AD"	1,6	WSCH/SCF13-150/BT40	5100443
SC16	4-16	40.0	90	52.0	63	M18	16	Form "AD"	1,4	WSCH/SCF16-90/BT40	5100444
SC16	4-16	40.0	120	52.0	93	M18	16	Form "AD"	1,7	WSCH/SCF16-120/BT40	5100446
SC16	4-16	40.0	150	52.0	123	M18	16	Form "AD"	1,9	WSCH/SCF16-150/BT40	5100447
SC20	6-20	48.0	90	59.5	63	M22	16	Form "AD"	1,4	WSCH/SCF20-90/BT40	5100448
SC20	6-20	48.0	120	59.5	93	M22	16	Form "AD"	2,0	WSCH/SCF20-120/BT40	5100449
SC20	6-20	48.0	150	59.5	123	M22	16	Form "AD"	2,3	WSCH/SCF20-150/BT40	5100450
SC25	6-25	55.0	90	63.5	63	M28	25	Form "AD"	1,4	WSCH/SCF25-90/BT40	5100452
SC25	6-25	55.0	120	63.5	93	M28	25	Form "AD"	2,1	WSCH/SCF25-120/BT40	5100453
SC25	6-25	55.0	150	63.5	123	M28	25	Form "AD"	2,6	WSCH/SCF25-150/BT40	5100456

Zubehör
Accessories

Ersatzteile
Spare Parts

Ersatzteile und Zubehör / Spare Parts & Accessories: Pg.D13 Pg.D15 Pg.D14 Pg.D7

• Im Lieferumfang enthalten: mit Spannmutter (gewuchtet) und Verstellerschraube • Delivery includes: Clamping nut (friction type), Adjusting screw

Super collet Spannzangenfutter
Super collet chuck

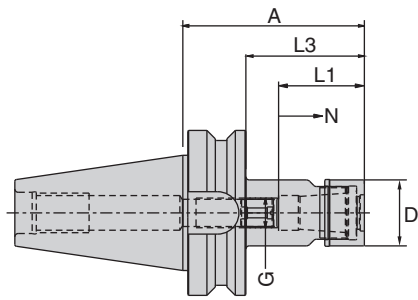

BT 50											
Spannzange Collet Type	Bereich Range	D (mm)	A (mm)	L1 (mm)	L3 (mm)	G (mm)	N (mm)	Kühlmittelzufuhr Coolant supply	N/W (Kg)	Bezeichnung Designation	Ident No.
SC06	2-6	19.5	105	31.5	67	M8	12	Form "AD"	3,8	WSCH/SCF06-105/BT50	5100457
SC06	2-6	19.5	135	31.5	97	M8	12	Form "AD"	3,8	WSCH/SCF06-135/BT50	5100458
SC06	2-6	19.5	165	31.5	127	M8	12	Form "AD"	3,9	WSCH/SCF06-165/BT50	5100459
SC10	2-10	27.1	105	35.0	67	M12	12	Form "AD"	3,9	WSCH/SCF10-105/BT50	5100460
SC10	2-10	27.1	135	35.0	97	M12	12	Form "AD"	3,9	WSCH/SCF10-135/BT50	5100461
SC10	2-10	27.1	165	35.0	127	M12	12	Form "AD"	4,0	WSCH/SCF10-165/BT50	5100462
SC13	3-13	33.0	105	43.0	67	M15	16	Form "AD"	4,0	WSCH/SCF13-105/BT50	5101997
SC13	3-13	33.0	135	43.0	97	M15	16	Form "AD"	4,2	WSCH/SCF13-135/BT50	5101998
SC13	3-13	33.0	165	43.0	127	M15	16	Form "AD"	4,4	WSCH/SCF13-165/BT50	5101999
SC16	4-16	40.0	105	52.0	67	M18	16	Form "AD"	4,1	WSCH/SCF16-105/BT50	5102000
SC16	4-16	40.0	135	52.0	97	M18	16	Form "AD"	4,4	WSCH/SCF16-135/BT50	5102001
SC16	4-16	40.0	165	52.0	127	M18	16	Form "AD"	4,6	WSCH/SCF16-165/BT50	5102002
SC20	6-20	48.0	105	59.5	67	M22	16	Form "AD"	4,2	WSCH/SCF20-105/BT50	5102003
SC20	6-20	48.0	135	59.5	97	M22	16	Form "AD"	4,6	WSCH/SCF20-135/BT50	5102004
SC20	6-20	48.0	165	59.5	127	M22	16	Form "AD"	4,9	WSCH/SCF20-165/BT50	5102005
SC25	6-25	55.0	105	63.5	67	M28	20	Form "AD"	4,3	WSCH/SCF25-105/BT50	5102006
SC25	6-25	55.0	135	63.5	97	M28	20	Form "AD"	4,7	WSCH/SCF25-135/BT50	5102007
SC25	6-25	55.0	165	63.5	127	M28	20	Form "AD"	5,2	WSCH/SCF25-165/BT50	5102008



Ersatzteile und Zubehör / Spare Parts & Accessories: Pg.D13 Pg.D15 Pg.D14 Pg.D7

• Im Lieferumfang enthalten: mit Spannmutter (gewuchtet) und Verstellerschraube • Delivery includes: Clamping nut (friction type), Adjusting screw

Fräseraufnahmen (Weldon) - für Zylinderschäfte gemäß DIN 1835B
 End mill holder (Weldon) - For cylindrical shanks according to DIN 1835B

BT MAS 403
 ISO7388-2

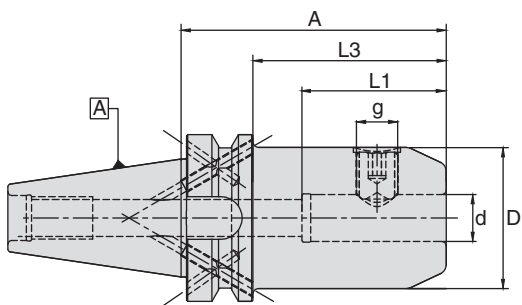

SK DIN 69871
 ISO7388-1

BT 30									
d (mm)	D (mm)	A (mm)	L1 (mm)	L3 (mm)	g	Kühlmittelezufuhr Coolant supply	N/W (Kg)	Bezeichnung Designation	Ident No.
06	25	50	37.0	28	M6	Form "AD"	0.6	WSLH/06-50/BT30	4600586
08	28	50	37.0	28	M8	Form "AD"	0.6	WSLH/08-50/BT30	4600587
10	35	50	41.0	28	M10	Form "AD"	0.8	WSLH/10-50/BT30	4600588
12	42	50	46.0	28	M12	Form "AD"	0.9	WSLH/12-50/BT30	4600589
14	44	50	46.0	28	M12	Form "AD"	0.9	WSLH/14-50/BT30	4600590
16	48	63	49.0	41	M14	Form "AD"	0.9	WSLH/16-63/BT30	4600591
18	50	63	49.0	41	M14	Form "AD"	1.0	WSLH/18-63/BT30	4600592
20	52	63	51.0	41	M16	Form "AD"	1.0	WSLH/20-63/BT30	5050529

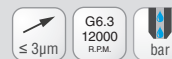

HSK DIN 69893

BT 40									
d (mm)	D (mm)	A (mm)	L1 (mm)	L3 (mm)	g	Kühlmittelezufuhr Coolant supply	N/W (Kg)	Bezeichnung Designation	Ident No.
16	48	35	49.0	8	M14	Form "AD"	1.0	WSLH/16-35/BT40*	5062796
20	52	35	51.0	8	M16	Form "AD"	1.0	WSLH/20-35/BT40*	5062797
25	45	35	59.0	8	M16	Form "AD"	0.9	WSLH/25-35/BT40*	5062798
32	63	65	63.0	38	M20	Form "AD"	1.5	WSLH/32-65/BT40*	5062799
06	25	50	37.0	23	M6	Form"AD/B"	1.0	WSLH/06-50/BT40	5062843
08	28	50	37.0	23	M8	Form"AD/B"	1.0	WSLH/08-50/BT40	5062846
10	35	63	41.0	36	M10	Form"AD/B"	1.1	WSLH/10-63/BT40	5062847
12	42	63	46.0	36	M12	Form"AD/B"	1.2	WSLH/12-63/BT40	5062848
14	44	63	46.0	36	M12	Form"AD/B"	1.2	WSLH/14-63/BT40	5062849
16	48	63	49.0	36	M14	Form"AD/B"	1.2	WSLH/16-63/BT40	5062851
18	50	63	49.0	36	M14	Form"AD/B"	1.4	WSLH/18-63/BT40	5062852
20	52	63	51.0	36	M16	Form"AD/B"	1.5	WSLH/20-63/BT40	5062853
25	65	90	59.0	63	M18	Form"AD/B"	2.0	WSLH/25-90/BT40 **	5062856
32	72	100	63.0	73	M20	Form"AD/B"	2.5	WSLH/32-100/BT40 **	5062883
40	80	120	73.0	93	M20	Form"AD/B"	3.0	WSLH/40-120/BT40 **	5062884
06	25	100	37.0	73	M6	Form"AD/B"	1.2	WSLH/06-100/BT40	5062897
08	28	100	37.0	73	M8	Form"AD/B"	1.2	WSLH/08-100/BT40	5062898
10	35	100	41.0	73	M10	Form"AD/B"	1.4	WSLH/10-100/BT40	5062899
12	42	100	46.0	73	M12	Form"AD/B"	1.6	WSLH/12-100/BT40	5062900
14	44	100	46.0	73	M12	Form"AD/B"	1.7	WSLH/14-100/BT40	5062901
16	48	100	49.0	73	M14	Form"AD/B"	1.7	WSLH/16-100/BT40	5062902
18	50	100	49.0	73	M14	Form"AD/B"	2.0	WSLH/18-100/BT40	5062903
20	52	100	51.0	73	M16	Form"AD/B"	2.0	WSLH/20-100/BT40	5062904
06	25	160	37.0	133	M6	Form"AD/B"	1.6	WSLH/06-160/BT40	5063409
08	28	160	37.0	133	M8	Form"AD/B"	1.7	WSLH/08-160/BT40	5063412
10	35	160	41.0	133	M10	Form"AD/B"	2.0	WSLH/10-160/BT40	5063413
12	42	160	46.0	133	M12	Form"AD/B"	2.2	WSLH/12-160/BT40	5063414
14	44	160	46.0	133	M12	Form"AD/B"	2.3	WSLH/14-160/BT40	5063415
16	48	160	49.0	133	M14	Form"AD/B"	2.6	WSLH/16-160/BT40	5063416
18	50	160	49.0	133	M14	Form"AD/B"	2.8	WSLH/18-160/BT40	5063417
20	52	160	51.0	133	M16	Form"AD/B"	2.9	WSLH/20-160/BT40	5063418
25	65	160	59.0	133	M18	Form"AD/B"	3.8	WSLH/25-160/BT40 **	5063419

Zubehör
 Accessories

Ersatzteile
 Spare Parts

Technische Spezifikationen
 Technical Details

Ersatzteile und Zubehör / Spare Parts & Accessories: Pg.D7 Pg.E2

- ** 2 Spanschrauben für ID Größe = 25 / 32 / 40 | Bohrungstoleranz H4
- * Extra kurze Aufnahmen: • Die Spanschrauben sind im Mitnehmer
- Maximale Steifigkeit dank kurzer Auskraglänge | • Im Lieferumfang enthalten: Spanschraube | • Höhere Wuchtgüte auf Anfrage
- ** 2 locking screws for ID size = 25 / 32 / 40 | Bore tolerance H4
- * Extra short holders: • Locking screws are located in the same plane as drive slots. • Gives maximum rigidity due to short projection
- Delivery includes: Locking screw | • Higher balancing grade on request

Fräseraufnahmen (Weldon) - für Zylinderschäfte gemäß DIN 1835B

End mill holder (Weldon) - For cylindrical shanks according to DIN 1835B

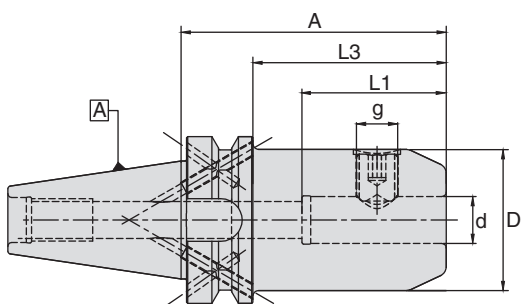

BT 50									
d (mm)	D (mm)	A (mm)	L1 (mm)	L3 (mm)	g	Kühlmittelzufuhr Coolant supply	N/W (Kg)	Bezeichnung Designation	Ident No.
06	25	63	37	25	M6	Form"AD/B"	3.5	WSLH/06-63/BT50	5063475
08	28	63	37	25	M8	Form"AD/B"	3.6	WSLH/08-63/BT50	5063476
10	35	63	41	25	M10	Form"AD/B"	3.7	WSLH/10-63/BT50	5063477
12	42	80	46	42	M12	Form"AD/B"	3.9	WSLH/12-80/BT50	5063478
14	44	80	46	42	M12	Form"AD/B"	3.9	WSLH/14-80/BT50	5063486
16	48	80	49	42	M14	Form"AD/B"	3.9	WSLH/16-80/BT50	5063487
18	50	80	49	42	M14	Form"AD/B"	4.0	WSLH/18-80/BT50	5063489
20	52	80	51	42	M16	Form"AD/B"	4.0	WSLH/20-80/BT50	5063491
25	65	100	59	62	M18	Form"AD/B"	4.7	WSLH/25-100/BT50 **	5063492
32	72	105	63	67	M20	Form"AD/B"	5.1	WSLH/32-105/BT50 **	5063493
40	80	110	73	72	M20	Form"AD/B"	6.5	WSLH/40-110/BT50 **	5063494
06	25	100	37	62	M6	Form"AD/B"	3.7	WSLH/06-100/BT50	5063549
08	28	100	37	62	M8	Form"AD/B"	3.7	WSLH/08-100/BT50	5063550
10	35	100	41	62	M10	Form"AD/B"	3.9	WSLH/10-100/BT50	5063551
12	42	100	46	62	M12	Form"AD/B"	4.1	WSLH/12-100/BT50	5063552
14	44	100	46	62	M12	Form"AD/B"	4.2	WSLH/14-100/BT50	5063553
16	48	100	49	62	M14	Form"AD/B"	4.2	WSLH/16-100/BT50	5063554
18	50	100	49	62	M14	Form"AD/B"	4.3	WSLH/18-100/BT50	5063555
20	52	100	51	62	M16	Form"AD/B"	4.3	WSLH/20-100/BT50	5063556
06	25	160	37	122	M6	Form"AD/B"	4.0	WSLH/06-160/BT50	5063560
08	28	160	37	122	M8	Form"AD/B"	4.1	WSLH/08-160/BT50	5063561
10	35	160	41	122	M10	Form"AD/B"	4.5	WSLH/10-160/BT50	5063562
12	42	160	46	122	M12	Form"AD/B"	4.6	WSLH/12-160/BT50	5063565
14	44	160	46	122	M12	Form"AD/B"	4.8	WSLH/14-160/BT50	5063566
16	48	160	49	122	M14	Form"AD/B"	5.0	WSLH/16-160/BT50	5063567
18	50	160	49	122	M14	Form"AD/B"	5.1	WSLH/18-160/BT50	5063568
20	52	160	51	122	M16	Form"AD/B"	5.2	WSLH/20-160/BT50	5063569
25	65	160	59	122	M18	Form"AD/B"	6.1	WSLH/25-160/BT50 **	5063570
32	72	160	63	122	M20	Form"AD/B"	6.7	WSLH/32-160/BT50 **	5063571

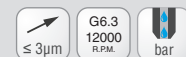

Ersatzteile und Zubehör / Spare Parts & Accessories:



- ** 2 Spanschrauben für ID Größe = 25 / 32 / 40
- Bohrungstoleranz H4
- Im Lieferumfang enthalten: Spanschraube
- Höhere Wuchtgüte auf Anfrage

- ** 2 locking screws for ID size = 25 / 32 / 40
- Bore tolerance H4
- Delivery includes: Locking screw
- Higher balancing grade on request

Fräseraufnahmen DIN 6359 mit Kühlkanal (für Zylinderschäfte gemäß DIN 1835 B)
 End mill holder to DIN 6359 with coolant channel (For cylindrical shanks according to DIN 1835B)

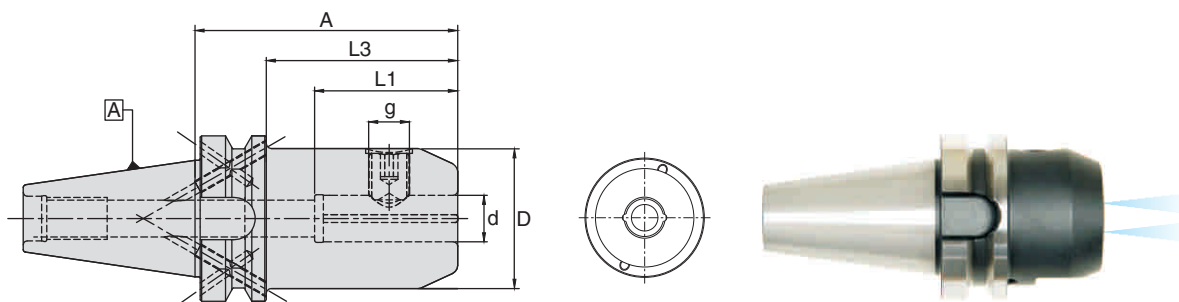

BT 40									
d (mm)	D (mm)	A (mm)	L1 (mm)	L3 (mm)	g	Kühlmittelzufuhr Coolant supply	N/W (Kg)	Bezeichnung Designation	Ident No.
16	48	35	49	8	M14	Form "AD"	1.0	WSLH-K/16-35/BT40*	5063572
20	52	35	51	8	M16	Form "AD"	1.0	WSLH-K/20-35/BT40*	5063573
25	45	35	59	8	M16	Form "AD"	0.9	WSLH-K/25-35/BT40*	5063574
32	63	65	63	38	M20	Form "AD"	1.5	WSLH-K/32-65/BT40*	5063575
06	25	50	37	23	M6	Form"AD/B"	1.0	WSLH-K/06-50/BT40	5063576
08	28	50	37	23	M8	Form"AD/B"	1.0	WSLH-K/08-50/BT40	5063577
10	35	63	41	36	M10	Form"AD/B"	1.1	WSLH-K/10-63/BT40	5063578
12	42	63	46	36	M12	Form"AD/B"	1.2	WSLH-K/12-63/BT40	5063579
14	44	63	46	36	M12	Form"AD/B"	1.2	WSLH-K/14-63/BT40	5063580
16	48	63	49	36	M14	Form"AD/B"	1.2	WSLH-K/16-63/BT40	5063581
18	50	63	49	36	M14	Form"AD/B"	1.1	WSLH-K/18-63/BT40	5063582
20	52	63	51	36	M16	Form"AD/B"	1.5	WSLH-K/20-63/BT40	5063583
25	65	90	59	63	M18	Form"AD/B"	2.3	WSLH-K/25-90/BT40 **	5063666
32	72	100	63	73	M20	Form"AD/B"	2.5	WSLH-K/32-100/BT40 **	5063667
40	80	120	73	93	M20	Form"AD/B"	3.0	WSLH-K/40-120/BT40 **	5063668

BT 50									
d (mm)	D (mm)	A (mm)	L1 (mm)	L3 (mm)	g	Kühlmittelzufuhr Coolant supply	N/W (Kg)	Bezeichnung Designation	Ident No.
06	25	63	37	25	M6	Form"AD/B"	3.5	WSLH-K/06-63/BT50	5063686
08	28	63	37	25	M8	Form"AD/B"	3.6	WSLH-K/08-63/BT50	5063687
10	35	63	41	25	M10	Form"AD/B"	3.7	WSLH-K/10-63/BT50	5063688
12	42	80	46	42	M12	Form"AD/B"	3.9	WSLH-K/12-80/BT50	5063689
14	44	80	46	42	M12	Form"AD/B"	3.9	WSLH-K/14-80/BT50	5063690
16	48	80	49	42	M14	Form"AD/B"	3.9	WSLH-K/16-80/BT50	5063691
18	50	80	49	42	M14	Form"AD/B"	4.0	WSLH-K/18-80/BT50	5063692
20	52	80	51	42	M16	Form"AD/B"	4.0	WSLH-K/20-80/BT50	5063693
25	65	100	59	62	M18	Form"AD/B"	4.7	WSLH-K/25-100/BT50 **	5063694
32	72	105	63	67	M20	Form"AD/B"	5.1	WSLH-K/32-105/BT50 **	5063695
40	80	110	73	72	M20	Form"AD/B"	6.5	WSLH-K/40-110/BT50 **	5063696

Ersatzteile und Zubehör / Spare Parts & Accessories: Pg.D7 Pg.E2

- Bohrungstoleranz H4
- Mit 2 Kühlkanälen entlang der Aufnahmebohrung versehen
- ** 2 Spanschrauben für ID Größe = 25 / 32 / 40
- * Extra kurze Aufnahmen:
- Die Spanschrauben sind im Mitnehmer
- Maximale Steifigkeit dank kurzer Auskraglänge
- Im Lieferumfang enthalten: Spanschraube
- Höhere Wuchtgüte auf Anfrage

- Bore tolerance H4
- With two coolant channels along the side of the bore
- ** 2 locking screws for ID size = 25 / 32 / 40
- * Extra short holders:
- Locking screws are located in the same plane as drive slots
- Gives maximum rigidity due to short projection.
- Delivery includes: Locking screw
- Higher balancing grade on request

Fräseraufnahmen DIN 6359 Whistle Notch (für Zylinderschäfte gemäß DIN 1835 E)

End mill holder to DIN 6359 Whistle Notch (For cylindrical shanks according to DIN 1835 E)

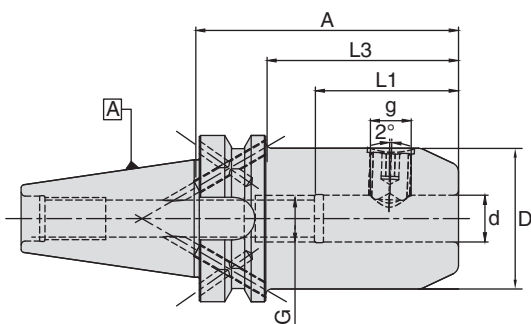

BT 40										
d (mm)	D (mm)	A (mm)	L1 (mm)	L3 (mm)	G	g	Kühlmittelzufuhr Coolant supply	N/W (Kg)	Bezeichnung Designation	Ident No.
06	25	50	37	23	M5	M6	Form"AD/B"	1.0	WSLH-E/06-50/BT40	5063751
08	28	50	37	23	M6	M8	Form"AD/B"	1.0	WSLH-E/08-50/BT40	5063752
10	35	63	41	36	M8	M10	Form"AD/B"	1.1	WSLH-E/10-63/BT40	5063753
12	42	63	46	36	M10	M12	Form"AD/B"	1.2	WSLH-E/12-63/BT40	5063754
14	44	63	46	36	M10	M12	Form"AD/B"	1.2	WSLH-E/14-63/BT40	5063757
16	48	63	49	36	M12	M14	Form"AD/B"	1.2	WSLH-E/16-63/BT40	5063758
18	50	63	49	36	M12	M14	Form"AD/B"	1.4	WSLH-E/18-63/BT40	5063759
20	52	63	51	36	M16	M16	Form"AD/B"	1.5	WSLH-E/20-63/BT40	5063760
25	65	90	59	63	M20	M18	Form"AD/B"	2.3	WSLH-E/25-90/BT40 **	5063761
32	72	100	63	73	M20	M20	Form"AD/B"	2.5	WSLH-E/32-100/BT40 **	5063762
40	80	120	73	93	M20	M20	Form"AD/B"	3.0	WSLH-E/40-120/BT40 **	5063763

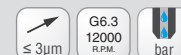

BT 50										
d (mm)	D (mm)	A (mm)	L1 (mm)	L3 (mm)	G	g	Kühlmittelzufuhr Coolant supply	N/W (Kg)	Bezeichnung Designation	Ident No.
06	25	63	37	25	M5	M6	Form"AD/B"	3.5	WSLH-E/06-63/BT50	4601432
08	28	63	37	25	M6	M8	Form"AD/B"	3.6	WSLH-E/08-63/BT50	4601433
10	35	63	41	25	M8	M10	Form"AD/B"	3.7	WSLH-E/10-63/BT50	4601434
12	42	80	46	42	M10	M12	Form"AD/B"	3.9	WSLH-E/12-80/BT50	4601435
14	44	80	46	42	M10	M12	Form"AD/B"	3.9	WSLH-E/14-80/BT50	4601436
16	48	80	49	42	M12	M14	Form"AD/B"	3.9	WSLH-E/16-80/BT50	4601437
18	50	80	49	42	M12	M14	Form"AD/B"	4.0	WSLH-E/18-80/BT50	4601438
20	52	80	51	42	M16	M16	Form"AD/B"	4.0	WSLH-E/20-80/BT50	4601439
25	65	100	59	62	M20	M18	Form"AD/B"	4.7	WSLH-E/25-100/BT50 **	4601440
32	72	105	63	67	M20	M20	Form"AD/B"	5.1	WSLH-E/32-105/BT50 **	4601441
40	80	115	73	77	M20	M20	Form"AD/B"	6.5	WSLH-E/40-115/BT50 **	5064367

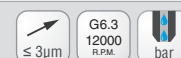

Ersatzteile und Zubehör / Spare Parts & Accessories:



- Bohrungstoleranz H4
- ** 2 Spannschrauben für ID Größe = 25 / 32 / 40
- Stirnseitige Nut als Erkennungsmerkmal (im Unterschied zu Weldon)
- Im Lieferumfang enthalten: Spannschraube und Verstellechraube
- Höhere Wuchtgüte auf Anfrage

- Bore tolerance H4
- ** 2 locking screws for ID size = 25 / 32 / 40
- Groove on face for easy identification (to distinguish from Weldon)
- Delivery includes: Locking screw & adjusting screw
- Higher balancing grade on request

Hochleistungsfräserspannfutter
Hi-Power Milling Chuck

BT MAS 403
ISO7388-2

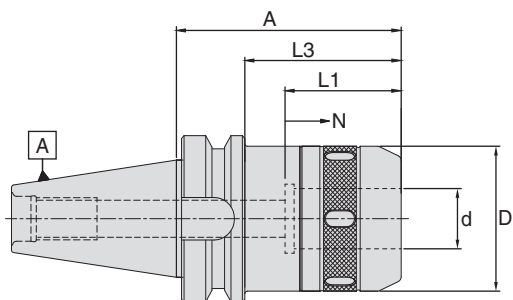

BT 30									
d (mm)	D (mm)	A (mm)	L1 (mm)	L3 (mm)	N	Kühlmittelezufuhr Coolant supply	N/W (Kg)	Bezeichnung Designation	Ident No.
20	52	90	60	68	15	Form "AD"	1.4	WHPMC/20-90/BT30	5066331
25	58	90	70	68	15	Form "AD"	1.4	WHPMC/25-90/BT30	5066332
32	66	105	75	83	15	Form "AD"	1.8	WHPMC/32-105/BT30	5066333

SK DIN 69871
ISO7388-1

BT 40									
d (mm)	D (mm)	A (mm)	L1 (mm)	L3 (mm)	N	Kühlmittelezufuhr Coolant supply	N/W (Kg)	Bezeichnung Designation	Ident No.
20	52	90	60	63	15	Form "AD"	1.9	WHPMC/20-90/BT40	5061428
25	58	90	70	63	15	Form "AD"	1.9	WHPMC/25-90/BT40	5065112
32	66	105	75	78	15	Form "AD"	2.4	WHPMC/32-105/BT40	5061429

HSK DIN 69893

BT 50									
d (mm)	D (mm)	A (mm)	L1 (mm)	L3 (mm)	N	Kühlmittelezufuhr Coolant supply	N/W (Kg)	Bezeichnung Designation	Ident No.
20	52	90	60	52	15	Form "AD"	4.5	WHPMC/20-90/BT50	5061430
25	58	90	60	52	15	Form "AD"	4.5	WHPMC/25-90/BT50	5065113
32	66	105	75	67	15	Form "AD"	5.0	WHPMC/32-105/BT50	5061431

Zubehör
Accessories

Ersatzteile und Zubehör / Spare Parts & Accessories: Pg.D10 Pg.D10 Pg.D7

Technische Details siehe Seite F7-F8 / For Technical details refer page F7-F8

Ersatzteile
Spare Parts

Technische Spezifikationen
Technical Details

Schlanke Hochleistungsfräserspannfutter
Slim Hi-Power Milling Chuck

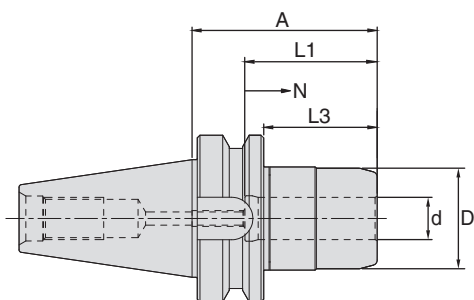

BT 30									
d (mm)	D (mm)	A (mm)	L1 (mm)	L3 (mm)	N	Kühlmittelzufuhr Coolant Supply	N/W (Kg)	Bezeichnung Designation	Ident No.
6	25	100	36	78	8	Form "AD"	0,9	WHPMC/S06-100/BT30	5105329
8	25	100	36	78	8	Form "AD"	0,9	WHPMC/S08-100/BT30	5105331
10	30	100	42	78	8	Form "AD"	0,9	WHPMC/S10-100/BT30	5105332
12	30	70	45	48	8	Form "AD"	0,9	WHPMC/S12-70/BT30	5097447
12	30	120	45	48	8	Form "AD"	1,3	WHPMC/S12-120/BT30	5097450
16	38	70	50	48	10	Form "AD"	0,9	WHPMC/S16-70/BT30	5097451
16	38	120	50	48	10	Form "AD"	1,3	WHPMC/S16-120/BT30	5097452

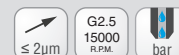

BT 40									
d (mm)	D (mm)	A (mm)	L1 (mm)	L3 (mm)	N	Kühlmittelzufuhr Coolant Supply	N/W (Kg)	Bezeichnung Designation	Ident No.
6	25	100	36	73	8	Form "AD"	1,7	WHPMC/S06-100/BT40	5105333
8	25	100	36	73	8	Form "AD"	1,7	WHPMC/S08-100/BT40	5105334
10	30	100	42	73	8	Form "AD"	1,7	WHPMC/S10-100/BT40	5105335
12	30	70	45	43	8	Form "AD"	1,7	WHPMC/S12-70/BT40	5097453
12	30	120	45	93	8	Form "AD"	2,1	WHPMC/S12-120/BT40	5097454
16	38	70	50	43	10	Form "AD"	1,5	WHPMC/S16-70/BT40	5097455
16	38	120	50	93	10	Form "AD"	1,9	WHPMC/S16-120/BT40	5097456
20	44	90	55	63	10	Form "AD"	2,0	WHPMC/S20-90/BT40	5097459
20	44	150	55	123	10	Form "AD"	2,5	WHPMC/S20-150/BT40	5097460

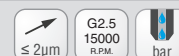

BT 50									
d (mm)	D (mm)	A (mm)	L1 (mm)	L3 (mm)	N	Kühlmittelzufuhr Coolant Supply	N/W (Kg)	Bezeichnung Designation	Ident No.
12	30	90	45	52	8	Form "AD"	5.1	WHPMC/S12-90/BT50	5097461
12	30	120	45	82	8	Form "AD"	5.5	WHPMC/S12-120/BT50	5097463
16	38	90	50	52	10	Form "AD"	5.2	WHPMC/S16-90/BT50	5097465
16	38	120	50	82	10	Form "AD"	5.7	WHPMC/S16-120/BT50	5097468
20	44	100	55	52	10	Form "AD"	5.0	WHPMC/S20-100/BT50	5097471
20	44	150	55	112	10	Form "AD"	5.5	WHPMC/S20-150/BT50	5097473

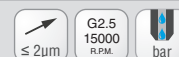

Ersatzteile und Zubehör / Spare Parts & Accessories: Pg.D10 Pg.D7

Technische Details siehe Seite F7-F8 / For Technical details refer page F7-F8

Hydrodehnspannfutter
Hydraulic expansion chuck

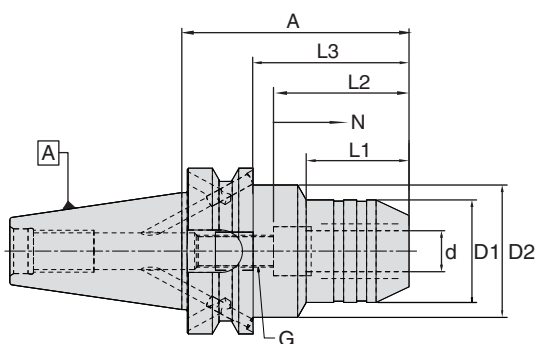

BT MAS 403
ISO7388-2

SK DIN 69871
ISO7388-1

HSK DIN 69893

Zubehör
Accessories

Ersatzteile
Spare Parts

Technische Spezifikationen
Technical Details

BT 30

d (mm)	A	D1 (mm)	D2 (mm)	L1	L2	L3	G	N	Kühlmittelezufuhr Coolant supply	Bezeichnung Designation	Ident No.
06	70	26	44.5	27	29.5	48	M5X0.8	10	Form"AD/B"	WHEC/06-70/BT30	5066322
08	70	28	44.5	27	30.0	48	M6X1.0	10	Form"AD/B"	WHEC/08-70/BT30	5066324
10	75	30	44.5	32	31.0	53	M8X1.0	10	Form"AD/B"	WHEC/10-75/BT30	5066325
12	85	32	44.5	37	40.0	63	M10X1.0	10	Form"AD/B"	WHEC/12-85/BT30	5066326
14	85	34	44.5	37	40.0	63	M10X1.0	10	Form"AD/B"	WHEC/14-85/BT30	5066327
16	90	38	44.5	42	46.0	68	M12X1.0	10	Form"AD/B"	WHEC/16-90/BT30	5066328
20	90	42	44.5	42	48.0	68	M16X1.0	10	Form"AD/B"	WHEC/20-90/BT30	5066329

BT 40

d (mm)	D1 (mm)	D2 (mm)	A	L1	L2	L3	G	N	Kühlmittelezufuhr Coolant supply	Bezeichnung Designation	Ident No.
06	26	49.5	90	27	30	63	M5X0.8	10	Form"AD/B"	WHEC/06-90/BT40	5062989
08	28	49.5	90	27	30	63	M6X1.0	10	Form"AD/B"	WHEC/08-90/BT40	5062991
10	30	49.5	90	32	32	63	M8X1.0	10	Form"AD/B"	WHEC/10-90/BT40	5062992
12	32	49.5	90	37	35	63	M10X1.0	10	Form"AD/B"	WHEC/12-90/BT40	5062994
14	34	49.5	90	37	35	63	M10X1.0	10	Form"AD/B"	WHEC/14-90/BT40	5062995
16	38	49.5	90	42	40	63	M12X1.0	10	Form"AD/B"	WHEC/16-90/BT40	5062996
18	40	49.5	90	42	40	63	M12X1.0	10	Form"AD/B"	WHEC/18-90/BT40	5062997
20	42	49.5	90	42	40	63	M16X1.0	10	Form"AD/B"	WHEC/20-90/BT40	5062998
25	50	60.0	100	48	45	73	M16X1.0	10	Form"AD/B"	WHEC/25-100/BT40	5062999
32	60	60.0	105	55	50	78	M16X1.0	10	Form"AD/B"	WHEC/32-105/BT40	5063000

BT 50

d (mm)	D1 (mm)	D2 (mm)	A	L1	L2	L3	G	N	Kühlmittelezufuhr Coolant supply	Bezeichnung Designation	Ident No.
06	26	44.5	90	27	43.0	52	M5X0.8	10	Form"AD/B"	WHEC/06-90/BT50	5063003
08	28	44.5	90	27	44.5	52	M6X1.0	10	Form"AD/B"	WHEC/08-90/BT50	5063016
10	30	44.5	90	32	44.5	52	M8X1.0	10	Form"AD/B"	WHEC/10-90/BT50	5063017
12	32	44.5	90	37	44.5	52	M10X1.0	10	Form"AD/B"	WHEC/12-90/BT50	5063018
14	34	44.5	90	37	44.5	52	M10X1.0	10	Form"AD/B"	WHEC/14-90/BT50	5063019
16	38	44.5	90	42	44.5	52	M12X1.0	10	Form"AD/B"	WHEC/16-90/BT50	5063020
18	40	44.5	90	42	44.5	52	M12X1.0	10	Form"AD/B"	WHEC/18-90/BT50	5063022
20	42	44.5	90	42	44.5	52	M16X1.0	10	Form"AD/B"	WHEC/20-90/BT50	5063023
25	50	60.0	105	42	47.5	67	M16X1.0	10	Form"AD/B"	WHEC/25-105/BT50	5063024
32	60	60.0	115	42	-	77	M16X1.0	10	Form"AD/B"	WHEC/32-115/BT50	5063025

Ersatzteile und Zubehör / Spare Parts & Accessories:

Pg.D11

Pg.D7

NC Bohrfutter
NC Drill Chuck

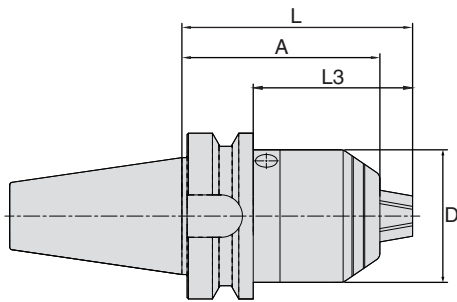

BT 40								
D (mm)	A (mm)	L (mm)	L3 (mm)	Bereich Range	Kühlmittelzufuhr Coolant supply	N/W (Kg)	Bezeichnung Designation	Ident No.
50	88	100	73	1-16	Form "A/AD"	1.80	WNDC/1-16-88/BT40	5064948

BT 50								
D (mm)	A (mm)	L (mm)	L3 (mm)	Bereich Range	Kühlmittelzufuhr Coolant supply	N/W (Kg)	Bezeichnung Designation	Ident No.
50	99	111	73	1-16	Form "A/AD"	3.90	WNDC/1-16-99/BT50	5064951

Zwischenhülsen für Morse-Kegel mit Anzugsgewinde DIN 6364 / 228A
Adaptor sleeves for Morse taper with thread DIN 6364 / 228A

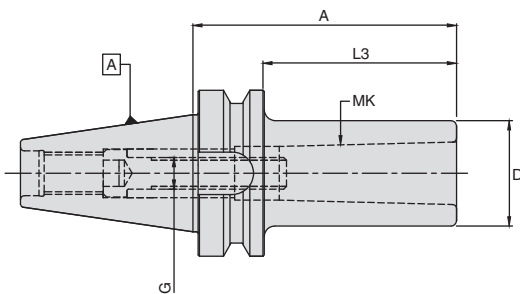

BT 40								
MK	D (mm)	A (mm)	L3 (mm)	G	Kühlmittelzufuhr Coolant supply	N/W (Kg)	Bezeichnung Designation	Ident No.
1	25	50	25	M6	-	1.1	WMTB/MT1-50/BT40	5064368
2	32	50	32	M10	-	1.1	WMTB/MT2-50/BT40	5064369
3	40	70	40	M12	-	1.3	WMTB/MT3-70/BT40	5064370
4	48	95	48	M16	-	1.5	WMTB/MT4-95/BT40	5064371



BT 50								
MK	D (mm)	A (mm)	L3 (mm)	G	Kühlmittelzufuhr Coolant supply	N/W (Kg)	Bezeichnung Designation	Ident No.
1	25	45	25	M6	-	3.8	WMTB/MT1-45/BT50	5064374
2	32	60	32	M10	-	3.6	WMTB/MT2-60/BT50	5064375
3	40	65	40	M12	-	3.6	WMTB/MT3-65/BT50	5064376
4	48	85	48	M16	-	3.7	WMTB/MT4-85/BT50	5064377
5	63	118	63	M20	-	3.8	WMTB/MT5-118/BT50	5064378



Ersatzteile und Zubehör / Spare Parts & Accessories: Pg.E5 Pg.D7 Pg.E5

• Im Lieferumfang enthalten: eingebaute Innensechskantschraube • Delivery includes: built-in draw screw

Zwischenhülsen für Morse-Kegel mit Austreibblappen DIN 6383
 Adaptor sleeves for Morse taper with tang to DIN 6383

BT MAS 403
 ISO7388-2

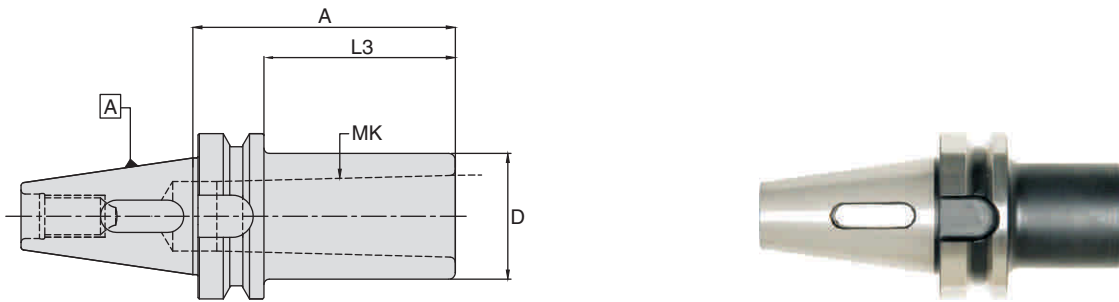

BT 30

MK	D (mm)	A (mm)	L3 (mm)	Kühlmittelzufuhr Coolant supply	N/W (Kg)	Bezeichnung Designation	Ident No.
1	25	45	23	-	0.5	WMTA/MT1-45/BT30	5066658
2	32	60	38	-	0.6	WMTA/MT2-60/BT30	5066659
3	40	75	53	-	0.8	WMTA/MT3-75/BT30	5066660

BT 40

MK	D (mm)	A (mm)	L3 (mm)	Kühlmittelzufuhr Coolant supply	N/W (Kg)	Bezeichnung Designation	Ident No.
1	25	50	23	-	1.0	WMTA/MT1-50/BT40	5064401
2	32	50	23	-	1.0	WMTA/MT2-50/BT40	5064402
3	40	70	43	-	1.1	WMTA/MT3-70/BT40	5064403
4	48	95	68	-	1.2	WMTA/MT4-95/BT40	5064404

BT 50

MK	D (mm)	A (mm)	L3 (mm)	Kühlmittelzufuhr Coolant supply	N/W (Kg)	Bezeichnung Designation	Ident No.
1	25	45	7	-	3.6	WMTA/MT1-45/BT50	5064405
2	32	60	22	-	3.7	WMTA/MT2-60/BT50	5064406
3	40	65	27	-	3.7	WMTA/MT3-65/BT50	5064407
4	48	95	57	-	4.5	WMTA/MT4-95/BT50	5064408
5	70	105	67	-	4.9	WMTA/MT5-105/BT50	5064410

Ersatzteile und Zubehör / Spare Parts & Accessories: Pg.D7

SK DIN 69871
 ISO7388-1

HSK DIN 69893

Zubehör
 Accessories

Ersatzteile
 Spare Parts

Technische Spezifikationen
 Technical Details

Aufnahme für Einschraubfräser
 Chuck for threaded milling heads

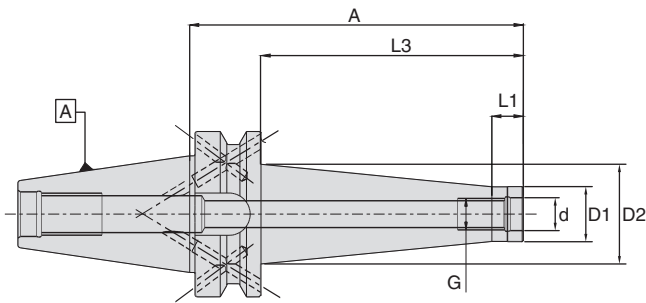

BT 40									
G	d (mm)	D1 (mm)	D2 (mm)	A (mm)	L1 (mm)	L3 (mm)	Kühlmittelezufuhr Coolant supply	Bezeichnung Designation	Ident No.
M8	8.5	13.8	15	52	12	25	Form"AD/B"	WTA/M8-52/BT40	5065018
M8	8.5	13.8	23	77	12	50	Form"AD/B"	WTA/M8-77/BT40	5065019
M8	8.5	13.8	25	102	12	75	Form"AD/B"	WTA/M8-102/BT40	5065020
M10	10.5	18.0	23	52	12	25	Form"AD/B"	WTA/M10-52/BT40	5065021
M10	10.5	18.0	25	77	12	50	Form"AD/B"	WTA/M10-77/BT40	5065022
M10	10.5	18.0	30	102	12	75	Form"AD/B"	WTA/M10-102/BT40	5065023
M12	12.5	21.0	24	52	12	25	Form"AD/B"	WTA/M12-52/BT40	5065024
M12	12.5	21.0	30	77	12	50	Form"AD/B"	WTA/M12-77/BT40	5065025
M12	12.5	21.0	35	102	12	75	Form"AD/B"	WTA/M12-102/BT40	5065031
M12	12.5	21.0	38	127	12	100	Form"AD/B"	WTA/M12-127/BT40	5065032
M16	17.0	29.0	29	52	12	25	Form"AD/B"	WTA/M16-52/BT40	5065034
M16	17.0	29.0	34	77	12	50	Form"AD/B"	WTA/M16-77/BT40	5065035
M16	17.0	29.0	35	102	12	75	Form"AD/B"	WTA/M16-102/BT40	5065036
M16	17.0	29.0	40	127	12	100	Form"AD/B"	WTA/M16-127/BT40	5065038
M16	17.0	29.0	48	152	12	125	Form"AD/B"	WTA/M16-152/BT40	5065040
M16	17.0	29.0	52	177	12	150	Form"AD/B"	WTA/M16-177/BT40	5065041

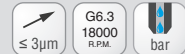

BT 50									
G	d (mm)	D1 (mm)	D2 (mm)	A (mm)	L1 (mm)	L3 (mm)	Kühlmittelezufuhr Coolant supply	Bezeichnung Designation	Ident No.
M12	12.5	21.0	35	88	12	50	Form"AD/B"	WTA/M12-88/BT50	5065046
M12	12.5	21.0	38	138	12	100	Form"AD/B"	WTA/M12-138/BT50	5065047
M12	12.5	21.0	48	188	12	150	Form"AD/B"	WTA/M12-188/BT50	5065048
M16	17.0	29.0	35	88	12	50	Form"AD/B"	WTA/M16-88/BT50	5065049
M16	17.0	29.0	40	113	12	75	Form"AD/B"	WTA/M16-113/BT50	5065050
M16	17.0	29.0	48	138	12	100	Form"AD/B"	WTA/M16-138/BT50	5065051
M16	17.0	29.0	52	188	12	150	Form"AD/B"	WTA/M16-188/BT50	5065052

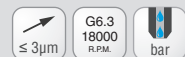

Ersatzteile und Zubehör / Spare Parts & Accessories: Pg.D7

Siehe Seite D12 für Einschraubfräser Verlängerung & Reduzierung

Refer page. D12 for Threaded Arbor extensions & reductions.

Aufsteckfräserdorn DIN 6358 mit Längs- und Quernut (Kombination)
Shell mill holder with DIN 6358 (Combination)

BT MAS 403
ISO7388-2

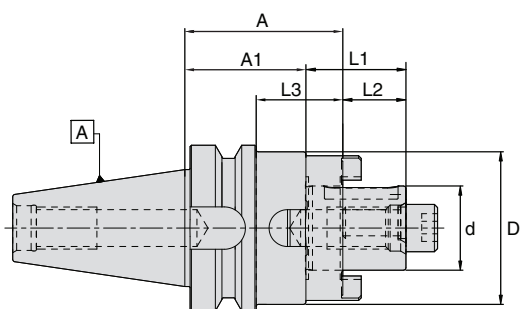

SK DIN 69871
ISO7388-1

BT 30										
d (mm)	D (mm)	A (mm)	A1 (mm)	L1 (mm)	L2 (mm)	L3 (mm)	Kühlmittelezufuhr Coolant supply	N/W (Kg)	Bezeichnung Designation	Ident No.
16	32	45	35	27	17	23	-	0.7	WFSH/16-45/BT30 *	6733419
22	40	47	35	31	19	25	-	0.8	WFSH/22-47/BT30 *	6733420
27	46	49	37	33	21	27	-	1.0	WFSH/27-49/BT30 *	6733421
16	32	80	70	27	17	58	-	0.9	WFSH/16-80/BT30 *	9202189
22	40	80	68	31	19	58	-	1.1	WFSH/22-80/BT30 *	9202190
27	48	90	78	33	21	68	-	1.3	WFSH/27-90/BT30 *	9202191

BT 40										
d (mm)	D (mm)	A (mm)	A1 (mm)	L1 (mm)	L2 (mm)	L3 (mm)	Kühlmittelezufuhr Coolant supply	N/W (Kg)	Bezeichnung Designation	Ident No.
16	32	55	45	27	17	28	-	1.1	WFSH/16-55/BT40	6733423
22	40	55	43	31	19	28	-	1.3	WFSH/22-55/BT40	6733425
27	48	55	43	33	21	28	-	1.5	WFSH/27-55/BT40	6733427
32	58	60	46	38	24	33	-	1.8	WFSH/32-60/BT40	6733429
40	70	60	46	41	27	33	-	2.1	WFSH/40-60/BT40 **	4600948
16	32	100	90	27	17	73	-	1.4	WFSH/16-100/BT40	6733424
22	40	100	88	31	19	73	-	1.8	WFSH/22-100/BT40	6733426
27	48	100	88	33	21	73	-	2.2	WFSH/27-100/BT40	6733428
32	58	100	86	38	24	73	-	2.6	WFSH/32-100/BT40	6733430
40	70	100	86	41	27	73	-	2.8	WFSH/40-100/BT40 **	4600949

HSK DIN 69893

Zubehör
Accessories

BT 50										
d (mm)	D (mm)	A (mm)	A1 (mm)	L1 (mm)	L2 (mm)	L3 (mm)	Kühlmittelezufuhr Coolant supply	N/W (Kg)	Bezeichnung Designation	Ident No.
16	32	70	60	27	17	32	-	3.8	WFSH/16-70/BT50	4601448
22	40	70	58	31	19	32	-	4.1	WFSH/22-70/BT50	4601449
27	48	70	58	33	21	32	-	4.2	WFSH/27-70/BT50	4601450
32	58	70	56	38	24	32	-	4.5	WFSH/32-70/BT50	4601451
40	70	70	56	41	27	32	-	5.0	WFSH/40-70/BT50 **	4601452

Ersatzteile
Spare Parts

Ersatzteile und Zubehör / Spare Parts & Accessories: Pg.E3 Pg.E4 Pg.E3 Pg.D8 Pg.D7

- Im Lieferumfang enthalten: Passfeder, Mitnehmerring, Fräseranzugsschraube und Spannschrauben (DIN 912)
- Delivery includes: Parallel key, drive ring, clamping screw and locking screw (DIN 912)
- * Im Lieferumfang enthalten: Spannschrauben (DIN 912 & DIN 6367)
- * Delivery includes: Locking screw (DIN 912 & DIN 6367)
- ** Im Lieferumfang enthalten: Spannschrauben (DIN 6367)
- ** Delivery includes: Locking screw (DIN 6367)

Technische Spezifikationen
Technical Details

Aufnahmedorn mit Innenzentrierung DIN 6357 mit vergrößertem Bunddurchmesser
Shell mill holder DIN 6357 for cutters with drive key

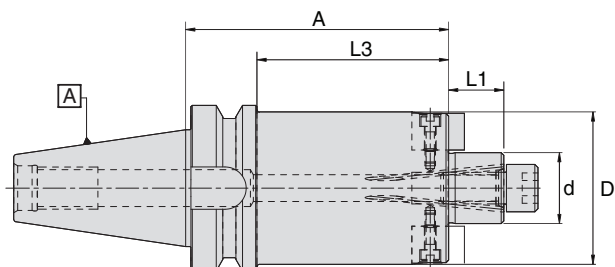

BT 30								
d (mm)	D (mm)	A (mm)	L1 (mm)	L3 (mm)	Kühlmittelzufuhr Coolant supply	N/W (Kg)	Bezeichnung Designation	Ident No.
16	38	40	17	18	-	0.7	WSMH/16-40/BT30*	5067575
22	48	40	19	18	-	0.9	WSMH/22-40/BT30*	5067577
27	58	40	21	18	-	1.0	WSMH/27-40/BT30*	5067578
32	78	50	24	8	-	1.8	WSMH/32-50/BT30*	5067579

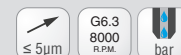

BT 40								
d (mm)	D (mm)	A (mm)	L1 (mm)	L3 (mm)	Kühlmittelzufuhr Coolant supply	N/W (Kg)	Bezeichnung Designation	Ident No.
16	38	40	17	13	Form"AD/B"	1.1	WSMH/16-40/BT40	5009952
22	48	40	19	13	Form"AD/B"	1.1	WSMH/22-40/BT40	5009953
27	58	40	21	13	Form"AD/B"	1.2	WSMH/27-40/BT40	5064794
32	78	50	24	23	Form"AD/B"	1.4	WSMH/32-50/BT40	5064795
40	88	50	27	23	Form"AD/B"	1.7	WSMH/40-50/BT40+	5064798
16	38	100	17	73	Form"AD/B"	1.7	WSMH/16-100/BT40	5064801
22	48	100	19	73	Form"AD/B"	2.2	WSMH/22-100/BT40	5064802
27	58	100	21	73	Form"AD/B"	2.6	WSMH/27-100/BT40	5064803
32	78	100	24	73	Form"AD/B"	3.7	WSMH/32-100/BT40	5064804
40	88	100	27	73	Form"AD/B"	4.3	WSMH/40-100/BT40+	5064805
16	38	160	17	133	Form"AD/B"	2.2	WSMH/16-160/BT40	5064806
22	48	160	19	133	Form"AD/B"	3.0	WSMH/22-160/BT40	5064810
27	58	160	21	133	Form"AD/B"	3.8	WSMH/27-160/BT40	5064827
32	78	160	24	133	Form"AD/B"	4.6	WSMH/32-160/BT40	5064829
40	88	160	27	133	Form"AD/B"	6.9	WSMH/40-160/BT40+	5064830

BT 50								
d (mm)	D (mm)	A (mm)	L1 (mm)	L3 (mm)	Kühlmittelzufuhr Coolant supply	N/W (Kg)	Bezeichnung Designation	Ident No.
16	38	63	17	25	Form"AD/B"	3.6	WSMH/16-63/BT50	5064832
22	48	63	19	25	Form"AD/B"	3.5	WSMH/22-63/BT50	5064834
27	58	63	21	25	Form"AD/B"	3.7	WSMH/27-63/BT50	5064835
32	78	60	24	22	Form"AD/B"	3.6	WSMH/32-60/BT50	5064836
40	88	60	27	22	Form"AD/B"	3.7	WSMH/40-60/BT50+	5064820
60	129	80	40	42	-	8.5	WSMH/60-80/BT50+	5064837
16	38	100	17	62	Form"AD/B"	4.0	WSMH/16-100/BT50	5064929
22	48	100	19	62	Form"AD/B"	4.3	WSMH/22-100/BT50	5064930
27	58	100	21	62	Form"AD/B"	4.7	WSMH/27-100/BT50	5064931
32	78	100	24	62	Form"AD/B"	5.8	WSMH/32-100/BT50	5064933
40	88	100	27	62	Form"AD/B"	6.4	WSMH/40-100/BT50+	5064934
16	38	160	17	122	Form"AD/B"	4.0	WSMH/16-160/BT50	5064936
22	48	160	19	122	Form"AD/B"	4.3	WSMH/22-160/BT50	5064937
27	58	160	21	122	Form"AD/B"	6.0	WSMH/27-160/BT50	5064938
32	78	160	24	122	Form"AD/B"	8.0	WSMH/32-160/BT50	5064940
40	88	160	27	122	Form"AD/B"	9.0	WSMH/40-160/BT50+	5064941

Ersatzteile und Zubehör / Spare Parts & Accessories:



- Kühlobstung an der Stirnseite Standard bei allen Grundhaltern
+ ID = Ø 40, D = Ø 60 Mit 4 zusätzlichen Gewindebohrungen nach DIN 2079
- Im Lieferumfang enthalten: Mitnehmersteine, Fräseranzugsschraube und Spannschrauben (DIN 912)
- * Im Lieferumfang enthalten: Spannschrauben (DIN 912 & DIN 6367)

- Coolant bore on the pilot face (holder with Form"AD/B") as standard for all holders
+ ID = Ø 40, D = Ø 60 With additional 4 screw holes to DIN 2079 and with locking screw (DIN 6367)
- Delivery includes: Drive keys, clamping screw and locking screw (DIN 912)
- * Delivery includes: Locking screw (both DIN 912 & DIN 6367)

Zwischenhülsen
Reduction Sleeves

BT MAS 403
ISO7388-2

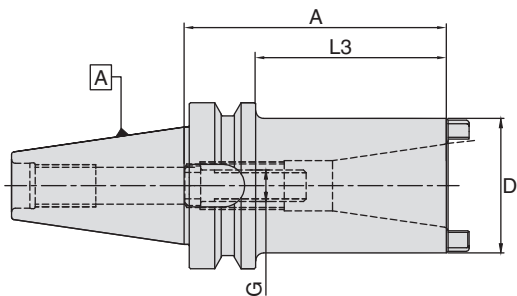

BT 40									
Innenkegelgröße Inside Taper	D (mm)	A (mm)	L3 (mm)	G	Kühlmittelezufuhr Coolant supply	N/W (Kg)	Bezeichnung Designation	Ident No.	
SK 30	51	60	33	M12	-	1.2	BT40-SK30-60	4600865	
SK 40	63	100	73	M16	-	1.7	BT40-SK40-100	4601866	

SK DIN 69871
ISO7388-1

BT 50									
Innenkegelgröße Inside Taper	D (mm)	A (mm)	L3 (mm)	G	Kühlmittelezufuhr Coolant supply	N/W (Kg)	Bezeichnung Designation	Ident No.	
SK 40	63	70	32	M16	-	4.1	BT50-SK40-70	4601387	
SK 50	97	120	82	M24	-	6.8	BT50-SK50-120	4601388	

HSK DIN 69893

Ersatzteile und Zubehör / Spare Parts & Accessories: Pg.E7 Pg.D7 Pg.E7

- Im Lieferumfang enthalten: eingebaute Innensechskantschraube
- Delivery includes: built-in draw screw

Bohrstangenrohlinge
Boring bar blanks

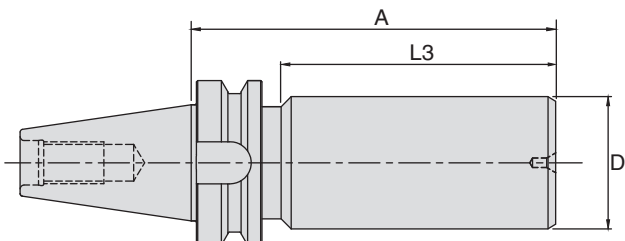

Zubehör
Accessories

BT 40							
D (mm)	A (mm)	L3 (mm)	Kühlmittelezufuhr Coolant supply	N/W (Kg)	Bezeichnung Designation	Ident No.	
63	250	223	Form"AD/B"	6.5	WBBB/63-250/BT40	5064955	

Ersatzteile
Spare Parts

BT 50							
D (mm)	A (mm)	L3 (mm)	Kühlmittelezufuhr Coolant supply	N/W (Kg)	Bezeichnung Designation	Ident No.	
63.5	300	262	Form"AD/B"	10.0	WBBB/63.5-300/BT50	5064956	

Ersatzteile und Zubehör / Spare Parts & Accessories: Pg.D7

- Im Lieferumfang enthalten: Steilkegel und Bund gehärtet und geschliffen, Schaft weich zur weiteren Bearbeitung
- Delivery includes: Steep taper and flange hardened, body left soft

Technische Spezifikationen
Technical Details

Kontrolldorn
Test Arbor

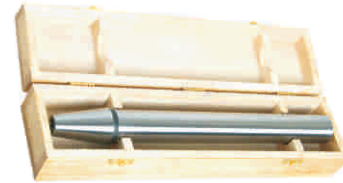
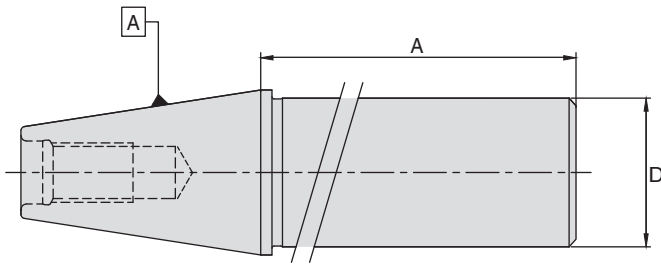

BT 40						↗ ≤ 2µm
D (mm)	A (mm)	Kühlmittelzufuhr Coolant supply	N/W (Kg)	Bezeichnung Designation	Ident No.	
40	330	-	3.0	WTMM/40-330/BT40	5083039	

BT 50						↗ ≤ 2µm
D (mm)	A (mm)	Kühlmittelzufuhr Coolant supply	N/W (Kg)	Bezeichnung Designation	Ident No.	
50	330	-	6.3	WTMM/50-330/BT50	5056227	

- Diese Dorne haben keinen Bund
- Kontrolldorne im Holzkasten geliefert

- These gauge are without flange
- Delivered in wooden box

Spannzangenfutter Typ ERC mit interner Kühlung
Collet chuck Type ERC with internal coolant (ER-IC / EX-IC coolant nut)

BT MAS 403
ISO7388-2

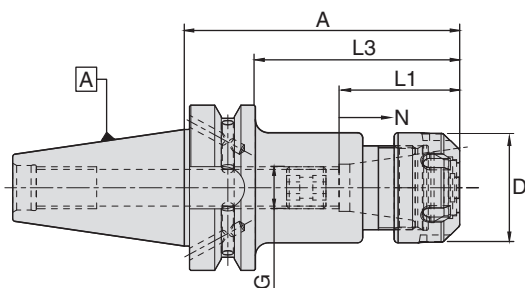

BT 30

≤ 3µm G6.3 15000 R.P.M. bar

Spannzange Collet Type	Bereich Range	D (mm)	A (mm)	L1 (mm)	L3 (mm)	G (mm)	N	Kühlmittelzufuhr Coolant supply	N/W (Kg)	Bezeichnung Designation	Ident No.
ER 16	1-10	28	75	32.5	53	M10	12	Form "AD"	0.7	WCCH/ERC16-75/BT30	5104129
ER 20	1-13	34	75	38	53	M12	12	Form "AD"	0.9	WCCH/ERC20-75/BT30	5104130
ER 25	2-16	42	75	41	53	M12	12	Form "AD"	0.6	WCCH/ERC25-75/BT30	5104131
ER 32	2-20	50	75	47	53	M12	12	Form "AD"	0.8	WCCH/ERC32-75/BT30	5104132
ER 16	1-10	28	105	32.5	83	M10	12	Form "AD"	0.7	WCCH/ERC16-105/BT30	5104134
ER 20	1-13	34	105	38	83	M12	12	Form "AD"	1.3	WCCH/ERC20-105/BT30	5104136
ER 25	2-16	42	105	41	83	M12	12	Form "AD"	0.6	WCCH/ERC25-105/BT30	5104137

SK DIN 69871
ISO7388-1

BT 40

≤ 3µm G6.3 15000 R.P.M. bar

Spannzange Collet Type	Bereich Range	D (mm)	A (mm)	L1 (mm)	L3 (mm)	G (mm)	N	Kühlmittelzufuhr Coolant supply	N/W (Kg)	Bezeichnung Designation	Ident No.
ER 16	1-10	28	75	32.5	48	M10	12	Form"AD/B"	1.0	WCCH/ERC16-75/BT40	5104138
ER 20	1-13	34	75	38	48	M12	12	Form"AD/B"	1.2	WCCH/ERC20-75/BT40	5104139
ER 25	2-16	42	75	41	48	M16	12	Form"AD/B"	1.0	WCCH/ERC25-75/BT40	5104141
ER 32	2-20	50	75	47	48	M22X1.5	12	Form"AD/B"	1.2	WCCH/ERC32-75/BT40	5104142
ER 40	3-26	63	85	58.5	58	M22X1.5	12	Form"AD/B"	1.2	WCCH/ERC40-85/BT40	5104143
ER 16	1-10	28	105	32.5	78	M10	12	Form"AD/B"	1.2	WCCH/ERC16-105/BT40	5104144
ER 20	1-13	34	105	38	78	M12	12	Form"AD/B"	1.4	WCCH/ERC20-105/BT40	5104145
ER 25	2-16	42	105	41	78	M16	12	Form"AD/B"	1.4	WCCH/ERC25-105/BT40	5104146
ER 32	2-20	50	105	47	78	M22X1.5	12	Form"AD/B"	1.5	WCCH/ERC32-105/BT40	5104147
ER 40	3-26	63	105	58.5	78	M22X1.5	12	Form"AD/B"	1.8	WCCH/ERC40-105/BT40	5104148
ER 16	1-10	28	165	32.5	138	M10	12	Form"AD/B"	1.6	WCCH/ERC16-165/BT40	5104149
ER 20	1-13	34	165	38	138	M12	12	Form"AD/B"	1.6	WCCH/ERC20-165/BT40	5104150
ER 25	2-16	42	165	41	138	M16	12	Form"AD/B"	2.1	WCCH/ERC25-165/BT40	5104151
ER 32	2-20	50	165	47	138	M22X1.5	12	Form"AD/B"	2.5	WCCH/ERC32-165/BT40	5104153
ER 40	3-26	63	165	58.5	138	M22X1.5	12	Form"AD/B"	2.6	WCCH/ERC40-165/BT40	5104154

HSK DIN 69893

Zubehör
Accessories

Ersatzteile und Zubehör / Spare Parts & Accessories: Pg.D7 Pg.D2 Pg.D4 Pg.D3

- Im Lieferumfang enthalten: Spannmutter (gewuchtet) und Einstellschraube
- Höhere Wuchtgüte auf Anfrage
- Delivery includes: Clamping nut (balanced) & adjusting screw
- Higher balancing grade on request

Ersatzteile
Spare Parts

- Die oben aufgeführten Artikel sind keine Lagerartikel und sind auf Anfrage erhältlich
- SK & HSK Artikel sind auf Anfrage erhältlich
- The above mentioned products are not stock articles and can be offered upon request
- SK & HSK taper holders can be offered upon request

Technische Spezifikationen
Technical Details

Spannzangenfutter Typ ERC mit interner Kühlung

Collet chuck Type ERC with internal coolant (ER-IC / EX-IC coolant nut)

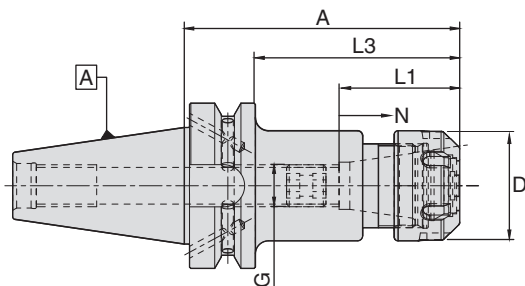

BT 50											
Spannzange Collet Type	Bereich Range	D (mm)	A (mm)	L1 (mm)	L3 (mm)	G (mm)	N	Kühlmittelzufuhr Coolant supply	N/W (Kg)	Bezeichnung Designation	Ident No.
ER 20	1-13	34	75	38	37	M12	12	Form"AD/B"	4.0	WCCH/ERC20-75/BT50	5104236
ER 25	2-16	42	75	41	37	M16	12	Form"AD/B"	3.4	WCCH/ERC25-75/BT50	5104237
ER 32	2-20	50	75	47	37	M22X1.5	12	Form"AD/B"	3.5	WCCH/ERC32-75/BT50	5104238
ER 40	3-26	63	85	58.5	47	M22X1.5	12	Form"AD/B"	3.6	WCCH/ERC40-85/BT50	5104239
ER 16	1-10	28	105	32.5	67	M10	12	Form"AD/B"	3.6	WCCH/ERC16-105/BT50	5104240
ER 20	1-13	34	105	38	67	M12	12	Form"AD/B"	4.0	WCCH/ERC20-105/BT50	5104241
ER 25	2-16	42	105	41	67	M16	12	Form"AD/B"	3.8	WCCH/ERC25-105/BT50	5104242
ER 32	2-20	50	105	47	67	M22X1.5	12	Form"AD/B"	3.9	WCCH/ERC32-105/BT50	5104243
ER 40	3-26	63	105	58.5	67	M22X1.5	12	Form"AD/B"	3.8	WCCH/ERC40-105/BT50	5104244
ER 16	1-10	28	165	32.5	127	M10	12	Form"AD/B"	4.1	WCCH/ERC16-165/BT50	5104245
ER 20	1-13	34	165	38	127	M12	12	Form"AD/B"	4.1	WCCH/ERC20-165/BT50	5104246
ER 25	2-16	42	165	41	127	M16	12	Form"AD/B"	4.1	WCCH/ERC25-165/BT50	5104247
ER 32	2-20	50	165	47	127	M22X1.5	12	Form"AD/B"	4.6	WCCH/ERC32-165/BT50	5104248
ER 40	3-26	63	165	58.5	127	M22X1.5	12	Form"AD/B"	4.6	WCCH/ERC40-165/BT50	5104249

Ersatzteile und Zubehör / Spare Parts & Accessories:

Pg.D7
 Pg.D2
 Pg.D4
 Pg.D3

• Im Lieferumfang enthalten: Spannmutter (gewuchtet) und Einstellschraube
 • Höhere Wuchtgüte auf Anfrage

• Delivery includes: Clamping nut (balanced) & adjusting screw
 • Higher balancing grade on request

- Die oben aufgeführten Artikel sind keine Lagerartikel und sind auf Anfrage erhältlich
- SK & HSK Artikel sind auf Anfrage erhältlich
- The above mentioned products are not stock articles and can be offered upon request
- SK & HSK taper holders can be offered upon request

Steilkegel mit Plananlage (FBT) Face Contact Holders (FBT)

Spannzangenfutter ER *
Collet chuck ER *

Super collet Spannzangenfutter *
Super collet chuck *

Fräseraufnahmen (Weldon) *
End mill holder (Weldon) *

Fräseraufnahmen (Whistle Notch) *
End mill holder (Whistle Notch) *

Hochleistungsfräaserspannfutter *
Hi-power milling chuck *

Schlanke Hochleistungsfräaserspannfutter *
Slim Hi-power milling chuck *

Hydrodehnspannfutter *
Hydraulic expansion chuck *

Aufnahmen für Morse-Kegel mit Anzugsgewinde *
Morse taper holder with thread *

Aufnahmen für Morse-Kegel mit Austreiblappen *
Morse taper holder with tang *

Aufnahmen für Einschraubfräser *
Chuck for threaded milling heads *

Kombi-Aufsteckfräserdorne *
Combi shell mill holder *

Messerkopf-Aufnahme *
Shell mill holder *

Reduzierhülsen *
Reduction Sleeves *

Bohrstangenrohlinge *
Boring bar blanks *

* Die oben aufgeführten Artikel sind keine Lagerartikel und sind auf Anfrage erhältlich
* The above mentioned products are not stock articles and can be offered upon request

SK DIN 69871
ISO7388-1

HSK DIN 69893

Zubehör
AccessoriesErsatzteile
Spare PartsTechnische Spezifikationen
Technical Details

DIN 69871 / ISO7388-1 (SK) Werkzeugaufnahmen

DIN 69871 / ISO7388-1 (SK) Tool Holders

Spannzangenfutter ER Collet chuck ER	B2 - B3
Super collet Spannzangenfutter Super collet chuck	B4
Fräseraufnahmen (Weldon) End mill holder (Weldon)	B5 - B7
Fräseraufnahmen (Whistle Notch) End mill holder (Whistle Notch)	B8
Hochleistungsfräaserspannfutter Hi-power milling chuck	B9
Schlanke Hochleistungsfräaserspannfutter Slim Hi-power milling chuck	B10
Hydrodehnspannfutter Hydraulic expansion chuck	B11
NC Bohrfutter NC Drill chuck	B12
Aufnahmen für Morse-Kegel mit Anzugsgewinde Morse taper holder with thread	B12
Aufnahmen für Morse-Kegel mit Austreibklappen Morse taper holder with tang	B13
Aufnahmen für Einschraubfräser Chuck for threaded milling heads	B14
Kombi-Aufsteckfräserdorne Combi shell mill holder	B15
Messerkopf-Aufnahme Shell mill holder	B16
Reduzierhülsen Reduction Sleeves	B17
Bohrstangenrohlinge Boring bar blanks	B17
Kontrolldorn Test Arbor	B18

Spannzangenfutter Typ ER für Spannzangen DIN 6499
Collet chuck Type ER for collets to DIN 6499

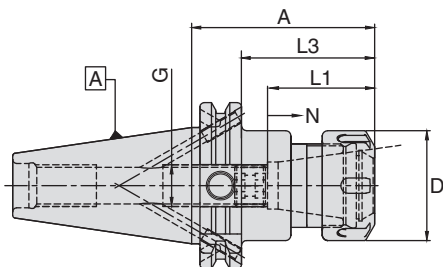

SK 30											
Spannzange Collet Type	Bereich Range	D (mm)	A (mm)	L1 (mm)	L3 (mm)	G	N	Kühlmittelezufuhr Coolant supply	N/W (Kg)	Bezeichnung Designation	Ident No.
ER16	1-10	28	70	33	50.9	M10	12	Form "AD"	0.7	WCCH/ER16-70/SK30	6733310
ER25	2-16	42	70	41	50.9	M12	12	Form "AD"	0.7	WCCH/ER25-70/SK30	4600545
ER32	2-20	50	70	47	50.9	M12	12	Form "AD"	0.8	WCCH/ER32-70/SK30	4600547
ER16	1-10	28	100	33	80.9	M10	12	Form "AD"	0.8	WCCH/ER16-100/SK30	6733311
ER25	2-16	42	100	33	80.9	M12	12	Form "AD"	0.9	WCCH/ER25-100/SK30	4600546
ER32	2-20	50	100	38	80.9	M12	12	Form "AD"	1.1	WCCH/ER32-100/SK30	4600548

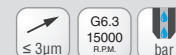

SK 40											
Spannzange Collet Type	Bereich Range	D (mm)	A (mm)	L1 (mm)	L3 (mm)	G	N	Kühlmittelezufuhr Coolant supply	N/W (Kg)	Bezeichnung Designation	Ident No.
ER16	1-10	28	70	32.5	50.9	M10	12	Form "AD/B"	1.0	WCCH/ER16-70/SK40	6733316
ER20	1-13	34	70	38	50.9	M12	12	Form "AD/B"	1.1	WCCH/ER20-70/SK40	6733319
ER25	2-16	42	70	41	50.9	M16	12	Form "AD/B"	1.1	WCCH/ER25-70/SK40	6733322
ER32	2-20	50	70	47	50.9	M22X1.5	12	Form "AD/B"	1.2	WCCH/ER32-70/SK40	6733325
ER40	3-26	63	80	58.5	60.9	M22X1.5	12	Form "AD/B"	1.5	WCCH/ER40-80/SK40	6733328
ER16	1-10	28	100	32.5	80.9	M10	12	Form "AD/B"	1.2	WCCH/ER16-100/SK40	6733317
ER20	1-13	34	100	38	80.9	M12	12	Form "AD/B"	1.3	WCCH/ER20-100/SK40	6733320
ER25	2-16	42	100	41	80.9	M16	12	Form "AD/B"	1.3	WCCH/ER25-100/SK40	6733323
ER32	2-20	50	100	47	80.9	M22X1.5	12	Form "AD/B"	1.5	WCCH/ER32-100/SK40	6733326
ER40	3-26	63	100	58.5	80.9	M22X1.5	12	Form "AD/B"	1.8	WCCH/ER40-100/SK40	6733329
ER16	1-10	28	160	32.5	140.9	M10	12	Form "AD/B"	1.6	WCCH/ER16-160/SK40	4600735
ER20	1-13	34	160	38	140.9	M12	12	Form "AD/B"	1.6	WCCH/ER20-160/SK40	5055182
ER25	2-16	42	160	41	140.9	M16	12	Form "AD/B"	1.7	WCCH/ER25-160/SK40	4600738
ER32	2-20	50	160	47	140.9	M22X1.5	12	Form "AD/B"	2.0	WCCH/ER32-160/SK40	4600741
ER40	3-26	63	160	58.5	140.9	M22X1.5	12	Form "AD/B"	2.0	WCCH/ER40-160/SK40	4600744

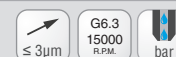

Ersatzteile und Zubehör / Spare Parts & Accessories:





- Datenträger-Bohrung (10 mm) Standard bei allen Grundhaltern
- Im Lieferumfang enthalten: Spannmutter (gewuchtet) und Einstellschraube
- Höhere Wuchtgüte auf Anfrage
- Innere Kühlmittelezufuhr auf Anfrage

- Data carrier bore (10 mm) as standard for all holders
- Delivery includes: Clamping nut (balanced) & adjusting screw
- Higher balancing grade on request
- Coolant nut based IRC on request

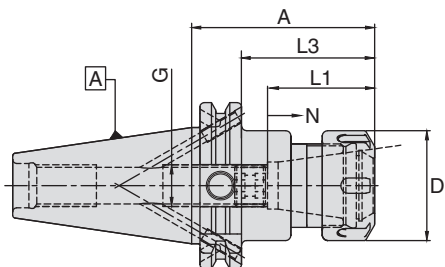
Spannzangenfutter Typ ER für Spannzangen DIN 6499
Collet chuck Type ER for collets to DIN 6499



SK 50											
  											
Spannzange Collet Type	Bereich Range	D (mm)	A (mm)	L1 (mm)	L3 (mm)	G	N	Kühlmittelezufuhr Coolant supply	N/W (Kg)	Bezeichnung Designation	Ident No.
ER16	1-10	28	63	32.5	43.9	M10	12	Form"AD/B"	3.0	WCCH/ER16-63/SK50	5055191
ER20	1-13	34	70	38	50.9	M12	12	Form"AD/B"	3.0	WCCH/ER20-70/SK50	5055192
ER25	2-16	42	70	41	50.9	M16	12	Form"AD/B"	3.0	WCCH/ER25-70/SK50	4601279
ER32	2-20	50	70	47	50.9	M22X1.5	12	Form"AD/B"	3.0	WCCH/ER32-70/SK50	4601282
ER40	3-26	63	80	58.5	60.9	M22X1.5	12	Form"AD/B"	3.3	WCCH/ER40-80/SK50	4601285
ER16	1-10	28	100	32.5	80.9	M10	12	Form"AD/B"	3.1	WCCH/ER16-100/SK50	4601277
ER20	1-13	34	100	38	80.9	M12	12	Form"AD/B"	3.2	WCCH/ER20-100/SK50	5055194
ER25	2-16	42	100	41	80.9	M16	12	Form"AD/B"	3.2	WCCH/ER25-100/SK50	4601280
ER32	2-20	50	100	47	80.9	M22X1.5	12	Form"AD/B"	3.2	WCCH/ER32-100/SK50	4601283
ER40	3-26	63	100	58.5	80.9	M22X1.5	12	Form"AD/B"	4.5	WCCH/ER40-100/SK50	4601286
ER16	1-10	28	160	32.5	140.9	M10	12	Form"AD/B"	3.6	WCCH/ER16-160/SK50	4601278
ER20	1-13	34	160	38	140.9	M12	12	Form"AD/B"	3.6	WCCH/ER20-160/SK50	5055195
ER25	2-16	42	160	41	140.9	M16	12	Form"AD/B"	3.7	WCCH/ER25-160/SK50	4601281
ER32	2-20	50	160	47	140.9	M22X1.5	12	Form"AD/B"	4.3	WCCH/ER32-160/SK50	4601284
ER40	3-26	63	160	58.5	140.9	M22X1.5	12	Form"AD/B"	5.3	WCCH/ER40-160/SK50	4601287

Ersatzteile und Zubehör / Spare Parts & Accessories:  Pg.D6  Pg.D2  Pg.D4  Pg.D3

- | | |
|--|--|
| <ul style="list-style-type: none"> • Datenträger-Bohrung (10mm) Standard bei allen Grundhaltern • Im Lieferumfang enthalten: Spannmutter (gewuchtet) und Einstellschraube • Höhere Wuchtgüte auf Anfrage • Innere Kühlmittelzufuhr auf Anfrage | <ul style="list-style-type: none"> • Data carrier bore (10 mm) as standard for all holders • Delivery includes: Clamping nut (balanced) & adjusting screw • Higher balancing grade on request • Coolant nut based IRC on request |
|--|--|

Super collet Spannzangenfutter
Super collet chuck

BT MAS 403
ISO7388-2

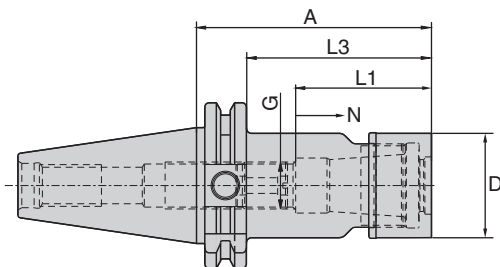

SK DIN 69871
ISO7388-1

SK 40

Spannzange Collet Type	Bereich Range	D (mm)	A (mm)	L1 (mm)	L3 (mm)	G (mm)	N (mm)	Kühlmittelezufuhr Coolant supply	N/W (Kg)	Bezeichnung Designation	Ident No.
SC06	2-6	19.5	90	31.5	85.9	M8	12	Form "AD"	1,0	WSCH/SCF06-90/SK40	5102046
SC06	2-6	19.5	120	31.5	115.9	M8	12	Form "AD"	1,0	WSCH/SCF06-120/SK40	5102048
SC06	2-6	19.5	150	31.5	145.9	M8	12	Form "AD"	1,1	WSCH/SCF06-150/SK40	5102050
SC10	2-10	27.1	90	35	85.9	M12	12	Form "AD"	1,1	WSCH/SCF10-90/SK40	5102051
SC10	2-10	27.1	120	35	115.9	M12	12	Form "AD"	1,2	WSCH/SCF10-120/SK40	5102053
SC10	2-10	27.1	150	35	145.9	M12	12	Form "AD"	1,3	WSCH/SCF10-150/SK40	5102057
SC13	3-13	33.0	90	43	85.9	M15	16	Form "AD"	1,2	WSCH/SCF13-90/SK40	5102059
SC13	3-13	33.0	120	43	115.9	M15	16	Form "AD"	1,3	WSCH/SCF13-120/SK40	5102060
SC13	3-13	33.0	150	43	145.9	M15	16	Form "AD"	1,5	WSCH/SCF13-150/SK40	5102061
SC16	4-16	40.0	90	52	85.9	M18	16	Form "AD"	1,3	WSCH/SCF16-90/SK40	5102062
SC16	4-16	40.0	120	52	115.9	M18	16	Form "AD"	1,6	WSCH/SCF16-120/SK40	5102063
SC16	4-16	40.0	150	52	145.9	M18	16	Form "AD"	1,8	WSCH/SCF16-150/SK40	5102068
SC20	6-20	48.0	90	59.5	85.9	M22	16	Form "AD"	1,5	WSCH/SCF20-90/SK40	5102070
SC20	6-20	48.0	120	59.5	115.9	M22	16	Form "AD"	1,9	WSCH/SCF20-120/SK40	5102071
SC20	6-20	48.0	150	59.5	145.9	M22	16	Form "AD"	2,3	WSCH/SCF20-150/SK40	5102072
SC25	6-25	55.0	90	63.5	85.9	M28	20	Form "AD"	1,4	WSCH/SCF25-90/SK40	5102073
SC25	6-25	55.0	120	63.5	115.9	M28	20	Form "AD"	1,7	WSCH/SCF25-120/SK40	5102074
SC25	6-25	55.0	150	63.5	145.9	M28	20	Form "AD"	2,0	WSCH/SCF25-150/SK40	5102075

HSK DIN 69893

SK 50

Spannzange Collet Type	Bereich Range	D (mm)	A (mm)	L1 (mm)	L3 (mm)	G (mm)	N (mm)	Kühlmittelezufuhr Coolant supply	N/W (Kg)	Bezeichnung Designation	Ident No.
SC06	2-6	19.5	105	31.5	85.9	M8	12	Form "AD"	2,9	WSCH/SCF06-105/SK50	5102076
SC06	2-6	19.5	135	31.5	115.9	M8	12	Form "AD"	2,9	WSCH/SCF06-135/SK50	5102077
SC06	2-6	19.5	165	31.5	145.9	M8	12	Form "AD"	3,0	WSCH/SCF06-165/SK50	5102078
SC10	2-10	27.1	105	35	85.9	M12	12	Form "AD"	3,0	WSCH/SCF10-105/SK50	5102079
SC10	2-10	27.1	135	35	115.9	M12	12	Form "AD"	3,1	WSCH/SCF10-135/SK50	5102080
SC10	2-10	27.1	165	35	145.9	M12	12	Form "AD"	3,2	WSCH/SCF10-165/SK50	5102081
SC13	3-13	33	105	43	85.9	M15	16	Form "AD"	3,1	WSCH/SCF13-105/SK50	5102082
SC13	3-13	33	135	43	115.9	M15	16	Form "AD"	3,2	WSCH/SCF13-135/SK50	5102083
SC13	3-13	33	165	43	145.9	M15	16	Form "AD"	3,4	WSCH/SCF13-165/SK50	5102084
SC16	4-16	40	105	52	85.9	M18	16	Form "AD"	3,3	WSCH/SCF16-105/SK50	5102085
SC16	4-16	40	135	52	115.9	M18	16	Form "AD"	3,5	WSCH/SCF16-135/SK50	5102086
SC16	4-16	40	165	52	145.9	M18	16	Form "AD"	3,8	WSCH/SCF16-165/SK50	5102087
SC20	6-20	48	105	59.5	85.9	M22	16	Form "AD"	3,6	WSCH/SCF20-105/SK50	5102088
SC20	6-20	48	135	59.5	115.9	M22	16	Form "AD"	3,9	WSCH/SCF20-135/SK50	5102089
SC20	6-20	48	165	59.5	145.9	M22	16	Form "AD"	4,2	WSCH/SCF20-165/SK50	5102091
SC25	6-25	55	105	63.5	85.9	M28	20	Form "AD"	3,3	WSCH/SCF25-105/SK50	5102092
SC25	6-25	55	135	63.5	115.9	M28	20	Form "AD"	3,6	WSCH/SCF25-135/SK50	5102093
SC25	6-25	55	165	63.5	145.9	M28	20	Form "AD"	4,0	WSCH/SCF25-165/SK50	5102095

Zubehör
Accessories

Ersatzteile
Spare Parts

Ersatzteile und Zubehör / Spare Parts & Accessories: Pg.D6 Pg.D13 Pg.D15 Pg.D14

- Im Lieferumfang enthalten: Spannmutter (gewuchtet) und Einstellschraube
- Delivery includes: Clamping nut (friction type), Adjusting screw

Technische Spezifikationen
Technical Details

Fräseraufnahme (Weldon) - für Zylinderschäfte gemäß DIN 1835 B
 End mill holder (Weldon) - For cylindrical shanks according to DIN 1835B

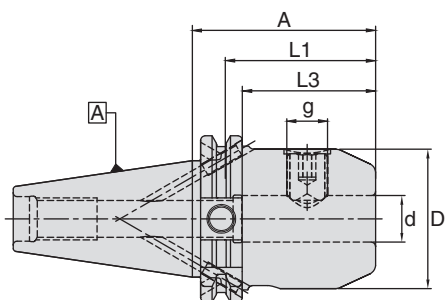

SK 40									
d (mm)	D (mm)	A (mm)	L1 (mm)	L3 (mm)	g	Kühlmittelzufuhr Coolant supply	N/W (Kg)	Bezeichnung Designation	Ident No.
16	48	35	49	15.9	M14	Form"AD"	1.0	WSLH/16-35/SK40*	4600771
20	50	35	51	15.9	M16	Form"AD"	1.0	WSLH/20-35/SK40*	4600782
25	50	35	59	15.9	M16	Form"AD"	1.0	WSLH/25-35/SK40*	4600788
32	50	65	63	45.9	M16	Form"AD"	1.2	WSLH/32-65/SK40*	4600792
06	25	50	37	30.9	M6	Form"AD/B"	1.0	WSLH/06-50/SK40	4600745
08	28	50	37	30.9	M8	Form"AD/B"	1.0	WSLH/08-50/SK40	4600750
10	35	50	41	30.9	M10	Form"AD/B"	1.1	WSLH/10-50/SK40	4600755
12	42	50	46	30.9	M12	Form"AD/B"	1.2	WSLH/12-50/SK40	4600760
14	44	50	46	30.9	M12	Form"AD/B"	1.2	WSLH/14-50/SK40	4600765
16	48	63	49	43.9	M14	Form"AD/B"	1.2	WSLH/16-63/SK40	4600770
18	50	63	49	43.9	M14	Form"AD/B"	1.4	WSLH/18-63/SK40	4600776
20	50	63	51	43.9	M16	Form"AD/B"	1.5	WSLH/20-63/SK40	4600781
06	25	100	37	80.9	M6	Form"AD/B"	1.2	WSLH/06-100/SK40	4600746
08	28	100	37	80.9	M8	Form"AD/B"	1.2	WSLH/08-100/SK40	4600751
10	35	100	41	80.9	M10	Form"AD/B"	1.4	WSLH/10-100/SK40	4600756
12	42	100	46	80.9	M12	Form"AD/B"	1.6	WSLH/12-100/SK40	4600761
14	44	100	46	80.9	M12	Form"AD/B"	1.7	WSLH/14-100/SK40	4600766
16	48	100	49	80.9	M14	Form"AD/B"	1.7	WSLH/16-100/SK40	4600772
18	50	100	49	80.9	M14	Form"AD/B"	2.0	WSLH/18-100/SK40	4600777
20	52	100	51	80.9	M16	Form"AD/B"	2.0	WSLH/20-100/SK40	4600783
25	65	100	59	80.9	M18	Form"AD/B"	2.7	WSLH/25-100/SK40 **	4600787
32	72	100	63	80.9	M20	Form"AD/B"	2.5	WSLH/32-100/SK40 **	4600791
40	80	120	73	100.9	M20	Form"AD/B"	3.0	WSLH/40-120/SK40 **	4600795
06	25	160	37	140.9	M6	Form"AD/B"	1.5	WSLH/06-160/SK40	4600748
08	28	160	37	140.9	M8	Form"AD/B"	1.5	WSLH/08-160/SK40	4600753
10	35	160	41	140.9	M10	Form"AD/B"	1.7	WSLH/10-160/SK40	4600758
12	42	160	46	140.9	M12	Form"AD/B"	2.2	WSLH/12-160/SK40	4600763
14	44	160	46	140.9	M12	Form"AD/B"	2.3	WSLH/14-160/SK40	4600768
16	48	160	49	140.9	M14	Form"AD/B"	1.7	WSLH/16-160/SK40	4600774
18	50	160	49	140.9	M14	Form"AD/B"	2.6	WSLH/18-160/SK40	4600779
20	52	160	51	140.9	M16	Form"AD/B"	2.8	WSLH/20-160/SK40	4600785
25	65	160	59	140.9	M18	Form"AD/B"	3.8	WSLH/25-160/SK40 **	4600789
32	72	160	63	140.9	M20	Form"AD/B"	4.4	WSLH/32-160/SK40 **	4600793

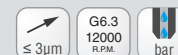

Ersatzteile und Zubehör / Spare Parts & Accessories: : Pg.D6

Pg.E2

- Datenträger-Bohrung (10mm) Standard bei allen Grundhaltern
- Bohrungstoleranz H4
- * Extra kurze Aufnahmen:
 - Die Spannschrauben sind im Mitnehmer
 - Maximale Steifigkeit dank kurzer Auskragslänge
- Im Lieferumfang enthalten: Spannschraube
- Höhere Wuchtgüte auf Anfrage
- ** 2 Spannschrauben für ID Größe = 25 / 32 / 40

- Data carrier bore (10mm) as standard for all holders
- Bore tolerance H4
- * Extra short holders:
 - Locking screws are located in the same plane as drive slots
 - Gives maximum rigidity due to short projection
- Delivery includes: Locking screw
- Higher balancing grade on request
- ** 2 locking screws for ID size = 25 / 32 / 40

Fräseraufnahme (Weldon) - für Zylinderschäfte gemäß DIN 1835 B
 End mill holder (Weldon) - For cylindrical shanks according to DIN 1835B

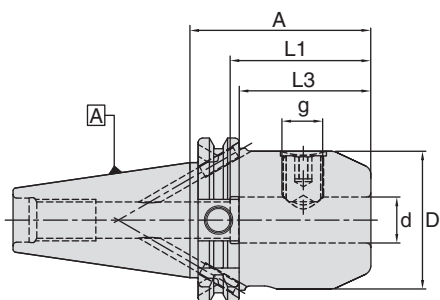

SK 50									
d (mm)	D (mm)	A (mm)	L1 (mm)	L3 (mm)	g	Kühlmittelzufuhr Coolant supply	N/W (Kg)	Bezeichnung Designation	Ident No.
06	25	63	37	43.9	M6	Form"AD/B"	2.7	WSLH/06-63/SK50	4601288
08	28	63	37	43.9	M8	Form"AD/B"	2.7	WSLH/08-63/SK50	4601292
10	35	63	41	43.9	M10	Form"AD/B"	2.9	WSLH/10-63/SK50	4601296
12	42	63	46	43.9	M12	Form"AD/B"	3.0	WSLH/12-63/SK50	4601300
14	44	63	46	43.9	M12	Form"AD/B"	3.0	WSLH/14-63/SK50	4601304
16	48	63	49	43.9	M14	Form"AD/B"	3.0	WSLH/16-63/SK50	4601308
18	50	63	49	43.9	M14	Form"AD/B"	3.0	WSLH/18-63/SK50	4601312
20	52	63	51	43.9	M16	Form"AD/B"	3.1	WSLH/20-63/SK50	4601316
25	65	80	59	60.9	M18	Form"AD/B"	3.7	WSLH/25-80/SK50	4601320
06	25	100	37	80.9	M6	Form"AD/B"	3.0	WSLH/06-100/SK50	4601289
08	28	100	37	80.9	M8	Form"AD/B"	3.0	WSLH/08-100/SK50	4601293
10	35	100	41	80.9	M10	Form"AD/B"	3.2	WSLH/10-100/SK50	4601297
12	42	100	46	80.9	M12	Form"AD/B"	3.4	WSLH/12-100/SK50	4601301
14	44	100	46	80.9	M12	Form"AD/B"	3.4	WSLH/14-100/SK50	4601305
16	48	100	49	80.9	M14	Form"AD/B"	3.6	WSLH/16-100/SK50	4601309
18	50	100	49	80.9	M14	Form"AD/B"	3.6	WSLH/18-100/SK50	4601313
20	52	100	51	80.9	M16	Form"AD/B"	3.7	WSLH/20-100/SK50	4601317
25	65	120	59	100.9	M18	Form"AD/B"	4.3	WSLH/25-120/SK50 **	4601321
32	72	100	63	80.9	M20	Form"AD/B"	5.1	WSLH/32-100/SK50 **	4601324
40	80	100	73	80.9	M20	Form"AD/B"	6.5	WSLH/40-100/SK50 **	5054934
06	25	160	37	140.9	M6	Form"AD/B"	3.4	WSLH/06-160/SK50	4601290
08	28	160	37	140.9	M8	Form"AD/B"	3.4	WSLH/08-160/SK50	4601294
10	35	160	41	140.9	M10	Form"AD/B"	3.9	WSLH/10-160/SK50	4601298
12	42	160	46	140.9	M12	Form"AD/B"	4.1	WSLH/12-160/SK50	4601302
14	44	160	46	140.9	M12	Form"AD/B"	4.1	WSLH/14-160/SK50	4601306
16	48	160	49	140.9	M14	Form"AD/B"	4.5	WSLH/16-160/SK50	4601310
18	50	160	49	140.9	M14	Form"AD/B"	4.6	WSLH/18-160/SK50	4601314
20	52	160	51	140.9	M16	Form"AD/B"	4.8	WSLH/20-160/SK50	4601318
25	65	160	59	140.9	M18	Form"AD/B"	6.0	WSLH/25-160/SK50 **	4601322
32	72	160	63	140.9	M20	Form"AD/B"	6.6	WSLH/32-160/SK50 **	4601325
40	80	160	73	140.9	M20	Form"AD/B"	6.9	WSLH/40-160/SK50 **	4601328

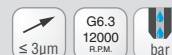

Ersatzteile und Zubehör / Spare Parts & Accessories :



- Datenträger-Bohrung (10 mm) Standard bei allen Grundhaltern
- Bohrungstoleranz H4
- Im Lieferumfang enthalten: Spannschraube
- Höhere Wuchtgüte auf Anfrage
- ** 2 Spannschrauben für ID Größe = 25 / 32 / 40

- Data carrier bore (10 mm) as standard for all holders
- Bore tolerance H4
- Delivery includes: Locking screw
- Higher balancing grade on request
- ** 2 locking screws for ID size = 25 / 32 / 40

BT MAS 403
ISO7388-2

SK DIN 69871
ISO7388-1

HSK DIN 69893

Zubehör
Accessories

Ersatzteile
Spare Parts

Technische Spezifikationen
Technical Details

Fräseraufnahme DIN 6359 mit Kühlkanal - für Zylinderschäfte gemäß DIN 1835 B

End mill holder to DIN 6359 with coolant channel (For cylindrical shanks according to DIN 1835B)

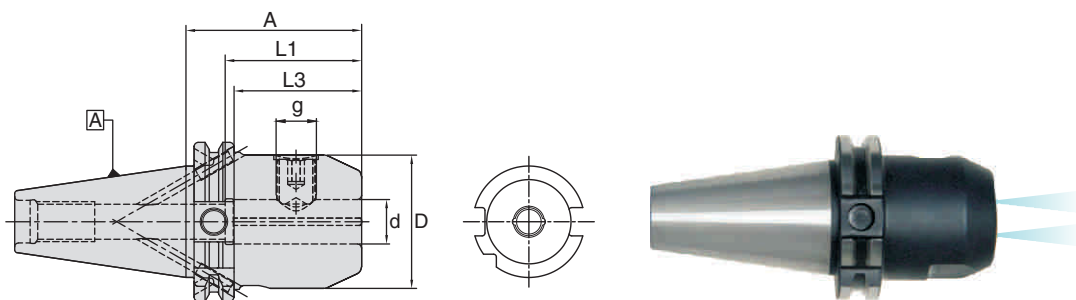

SK 40									
d (mm)	D (mm)	A (mm)	L1 (mm)	L3 (mm)	g	Kühlmittelzufuhr Coolant supply	N/W (Kg)	Bezeichnung Designation	Ident No.
06	25	50	37	30.9	M6	Form"AD/B"	0.9	WSLH-K/06-50/SK40	4600749
08	28	50	37	30.9	M8	Form"AD/B"	0.9	WSLH-K/08-50/SK40	4600754
10	35	50	41	30.9	M10	Form"AD/B"	1.0	WSLH-K/10-50/SK40	4600759
12	42	50	46	30.9	M12	Form"AD/B"	1.0	WSLH-K/12-50/SK40	4600764
14	44	50	46	30.9	M12	Form"AD/B"	1.0	WSLH-K/14-50/SK40	4600769
16	48	63	49	43.9	M14	Form"AD/B"	1.2	WSLH-K/16-63/SK40	4600775
18	50	63	49	43.9	M14	Form"AD/B"	1.3	WSLH-K/18-63/SK40	4600780
20	50	63	51	43.9	M16	Form"AD/B"	1.3	WSLH-K/20-63/SK40	4600786
06	25	100	37	80.9	M6	Form"AD/B"	1.1	WSLH-K/06-100/SK40	4600747
08	28	100	37	80.9	M8	Form"AD/B"	1.1	WSLH-K/08-100/SK40	4600752
10	35	100	41	80.9	M10	Form"AD/B"	1.3	WSLH-K/10-100/SK40	4600757
12	42	100	46	80.9	M12	Form"AD/B"	1.5	WSLH-K/12-100/SK40	4600762
14	44	100	46	80.9	M12	Form"AD/B"	1.6	WSLH-K/14-100/SK40	4600767
16	48	100	49	80.9	M14	Form"AD/B"	1.7	WSLH-K/16-100/SK40	4600773
18	50	100	49	80.9	M14	Form"AD/B"	1.8	WSLH-K/18-100/SK40	4600778
20	50	100	51	80.9	M16	Form"AD/B"	1.9	WSLH-K/20-100/SK40	4600784
25	65	100	59	80.9	M18	Form"AD/B"	2.3	WSLH-K/25-100/SK40 **	4600790
32	72	100	63	80.9	M20	Form"AD/B"	2.5	WSLH-K/32-100/SK40 **	4600794
40	80	120	73	100.9	M20	Form"AD/B"	3.4	WSLH-K/40-120/SK40 **	4600796

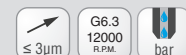

SK 40									
d (mm)	D (mm)	A (mm)	L1 (mm)	L3 (mm)	g	Kühlmittelzufuhr Coolant supply	N/W (Kg)	Bezeichnung Designation	Ident No.
06	25	63	37	43.9	M6	Form"AD/B"	2.7	WSLH-K/06-63/SK50	4601291
08	28	63	37	43.9	M8	Form"AD/B"	2.7	WSLH-K/08-63/SK50	4601295
10	35	63	41	43.9	M10	Form"AD/B"	2.8	WSLH-K/10-63/SK50	4601299
12	42	63	46	43.9	M12	Form"AD/B"	2.9	WSLH-K/12-63/SK50	4601303
14	44	63	46	43.9	M12	Form"AD/B"	2.9	WSLH-K/14-63/SK50	4601307
16	48	63	49	43.9	M14	Form"AD/B"	3.0	WSLH-K/16-63/SK50	4601311
18	50	63	49	43.9	M14	Form"AD/B"	3.0	WSLH-K/18-63/SK50	4601315
20	52	63	51	43.9	M16	Form"AD/B"	3.2	WSLH-K/20-63/SK50	4601319
25	65	80	59	60.9	M18	Form"AD/B"	4.6	WSLH-K/25-80/SK50 **	4601323
32	72	100	63	80.9	M20	Form"AD/B"	6.4	WSLH-K/32-100/SK50 **	4601326
40	80	100	73	80.9	M20	Form"AD/B"	7.3	WSLH-K/40-100/SK50 **	4601329

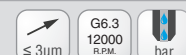

Ersatzteile und Zubehör / Spare Parts & Accessories: :



- Datenträger-Bohrung (10 mm) Standard bei allen Grundhaltern
- Bohrungstoleranz H4
- Extra kurze Aufnahmen:
 - Die Spannschrauben sind im Mitnehmer
 - Maximale Steifigkeit dank kurzer Auskragslänge
- Mit 2 Kühlkanälen entlang der Aufnahmebohrung versehen
- Im Lieferumfang enthalten: Spannschraube
- Höhere Wuchtgüte auf Anfrage
- ** 2 Spannschrauben für ID Größe = 25 / 32 / 40

- Data carrier bore (10mm) as standard for all holders
- Bore tolerance H4
- Extra short holders:
 - Locking screws are located in the same plane as drive slots
 - Gives maximum rigidity due to short projection
- With two coolant channels along the side of the bore
- Delivery includes: Locking screw
- Higher balancing grade on request
- ** 2 locking screws for ID size = 25 / 32 / 40

Fräseraufnahme DIN 6359 Whistle Notch - für Zylinderschäfte gemäß DIN 1835 E
 End mill holder to DIN 6359 Whistle Notch (For cylindrical shanks according to DIN 1835 E)

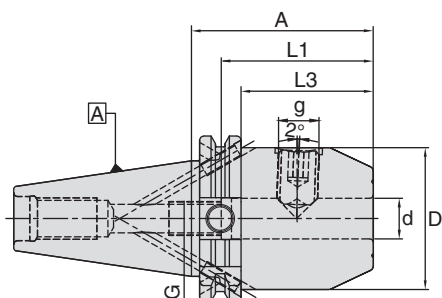

SK 40												
d (mm)	D (mm)	A (mm)	L1 (mm)	L3 (mm)	G	g	Kühlmittelzufuhr Coolant supply	N/W (Kg)	Bezeichnung Designation	Ident No.		
06	25	50	37	30.9	M5	M6	Form"AD/B"	1.0	WSLH-E/06-50/SK40	4600797		
08	28	50	37	30.9	M6	M8	Form"AD/B"	1.0	WSLH-E/08-50/SK40	4600798		
10	35	50	41	30.9	M8	M10	Form"AD/B"	1.1	WSLH-E/10-50/SK40	4600799		
12	42	50	46	30.9	M10	M12	Form"AD/B"	1.2	WSLH-E/12-50/SK40	4600800		
14	44	50	46	30.9	M10	M12	Form"AD/B"	1.2	WSLH-E/14-50/SK40	4600801		
16	48	63	49	43.9	M12	M14	Form"AD/B"	1.2	WSLH-E/16-63/SK40	4600802		
18	50	63	49	43.9	M12	M14	Form"AD/B"	1.4	WSLH-E/18-63/SK40	4600803		
20	50	63	51	43.9	M16	M16	Form"AD/B"	1.5	WSLH-E/20-63/SK40	4600804		
25	65	100	59	80.9	M20	M18	Form"AD/B"	2.3	WSLH-E/25-100/SK40 **	4600805		
32	72	100	63	80.9	M20	M20	Form"AD/B"	2.5	WSLH-E/32-100/SK40 **	4600806		
40	80	120	73	100.9	M20	M20	Form"AD/B"	3.0	WSLH-E/40-120/SK40 **	4600807		

SK 50												
d (mm)	D (mm)	A (mm)	L1 (mm)	L3 (mm)	G	g	Kühlmittelzufuhr Coolant supply	N/W (Kg)	Bezeichnung Designation	Ident No.		
06	25	63	37	43.9	M5	M6	Form"AD/B"	3.5	WSLH-E/06-63/SK50	4601330		
08	28	63	37	43.9	M6	M8	Form"AD/B"	3.6	WSLH-E/08-63/SK50	4601331		
10	35	63	41	43.9	M8	M10	Form"AD/B"	3.7	WSLH-E/10-63/SK50	4601332		
12	42	63	46	43.9	M10	M12	Form"AD/B"	3.9	WSLH-E/12-63/SK50	4601333		
14	44	63	46	43.9	M10	M12	Form"AD/B"	3.9	WSLH-E/14-63/SK50	4601334		
16	48	63	49	43.9	M12	M14	Form"AD/B"	3.9	WSLH-E/16-63/SK50	4601335		
18	50	63	49	43.9	M12	M14	Form"AD/B"	4.0	WSLH-E/18-63/SK50	4601336		
20	52	63	51	43.9	M16	M16	Form"AD/B"	4.0	WSLH-E/20-63/SK50	4601337		
25	65	80	59	60.9	M20	M18	Form"AD/B"	4.7	WSLH-E/25-80/SK50 **	4601338		
32	72	100	63	80.9	M20	M20	Form"AD/B"	5.1	WSLH-E/32-100/SK50 **	4601339		
40	80	100	73	80.9	M20	M20	Form"AD/B"	6.5	WSLH-E/40-100/SK50 **	4601340		

Ersatzteile und Zubehör / Spare Parts & Accessories: Pg.D6

Pg.E2

- Datenträger-Bohrung (10 mm) Standard bei allen Grundhaltern
- Bohrungstoleranz H4
- Stirnseitige Nut als Erkennungsmerkmal (im Unterschied zu Weldon)
- Im Lieferumfang enthalten: Spannschraube und Verstellerschraube
- Höhere Wuchtgüte auf Anfrage

** 2 Spannschrauben für ID Größe = 25 / 32 / 40

- Data carrier bore (10 mm) as standard for all holders
- Bore tolerance H4
- Groove on face for easy identification (to distinguish from Weldon)
- Delivery includes: Locking screw & Adjusting screw
- Higher balancing grade on request

** 2 locking screws for ID size = 25 / 32 / 40

BT MAS 403
ISO7388-2

SK DIN 69871
ISO7388-1

HSK DIN 69893

Zubehör
Accessories

Ersatzteile
Spare Parts

Technische Spezifikationen
Technical Details

Hochleistungsfräserspannfutter
Hi-Power Milling Chuck

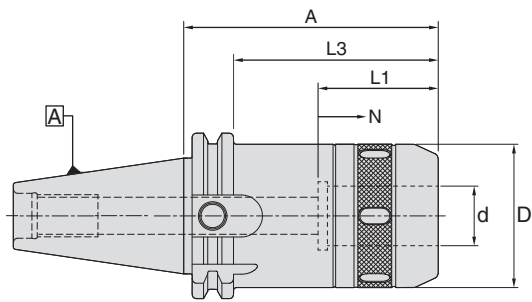

SK 40									
d (mm)	D (mm)	A (mm)	L1 (mm)	L3 (mm)	N	Kühlmittelzufuhr Coolant supply	N/W (Kg)	Bezeichnung Designation	Ident No.
20	52	90	60	71	15	Form "AD"	1.9	WHPMC/20-90/SK40	5058644
32	66	105	75	86	15	Form "AD"	2.4	WHPMC/32-105/SK40	5055618



SK 50									
d (mm)	D (mm)	A (mm)	L1 (mm)	L3 (mm)	N	Kühlmittelzufuhr Coolant supply	N/W (Kg)	Bezeichnung Designation	Ident No.
20	52	90	60	71	15	Form "AD"	2.8	WHPMC/20-90/SK50	5058645
32	66	105	75	86	15	Form "AD"	5.0	WHPMC/32-105/SK50	5055619

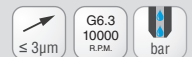

Ersatzteile und Zubehör / Spare Parts & Accessories: Pg.D10 Pg.D10 Pg.D6

Technische Details siehe Seite F7-F8
Refer page no.F7-F8 for more technical information

Schlanke Hochleistungsfräaserspannfutter
Slim Hi-Power Milling Chuck (Slim HPMC)

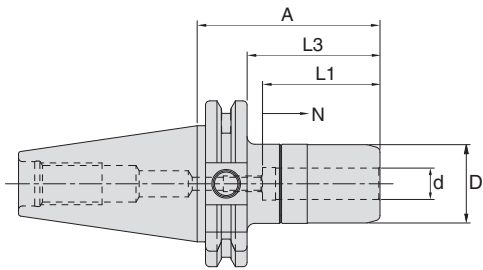

SK 40									
d (mm)	D (mm)	A (mm)	L1 (mm)	L3 (mm)	N	Kühlmittelzufuhr Coolant supply	N/W (Kg)	Bezeichnung Designation	Ident No.
6	25	100	36	81	8	Form "AD"	1.5	WHPMC/S06-100/SK40	5105336
8	25	100	36	81	8	Form "AD"	1.5	WHPMC/S08-100/SK40	5105337
10	30	100	42	81	8	Form "AD"	1.5	WHPMC/S10-100/SK40	5105338
12	30	70	45	50.9	8	Form "AD"	1.5	WHPMC/S12-70/SK40	5097477
12	30	120	45	100.9	8	Form "AD"	1.9	WHPMC/S12-120/SK40	5097478
16	38	70	50	50.9	10	Form "AD"	1.4	WHPMC/S16-70/SK40	5097479
16	38	120	50	100.9	10	Form "AD"	1.8	WHPMC/S16-120/SK40	5097482
20	44	90	55	70.9	10	Form "AD"	2.0	WHPMC/S20-90/SK40	5097483
20	44	150	55	130.9	10	Form "AD"	2.4	WHPMC/S20-150/SK40	5097485



SK 50									
d (mm)	D (mm)	A (mm)	L1 (mm)	L3 (mm)	N	Kühlmittelzufuhr Coolant supply	N/W (Kg)	Bezeichnung Designation	Ident No.
12	30	90	45	70.9	8	Form "AD"	4.0	WHPMC/S12-90/SK50	5097488
12	30	120	45	100.9	8	Form "AD"	4.4	WHPMC/S12-120/SK50	5097489
16	38	90	50	70.9	10	Form "AD"	3.5	WHPMC/S16-90/SK50	5097491
16	38	120	50	100.9	10	Form "AD"	3.8	WHPMC/S16-120/SK50	5097492
20	44	100	55	70.9	10	Form "AD"	4.5	WHPMC/S20-100/SK50	5097493
20	44	150	55	130.9	10	Form "AD"	5.0	WHPMC/S20-150/SK50	5097494



Ersatzteile und Zubehör / Spare Parts & Accessories: Pg.D10 Pg.D6

Technische Details siehe Seite F7-F8
Refer page no.F7-F8 for more technical information

BT MAS 403
ISO7388-2

SK DIN 69871
ISO7388-1

HSK DIN 69893

Zubehör
Accessories

Ersatzteile
Spare Parts

Technische Spezifikationen
Technical Details

Hydrodehnspannfutter
Hydraulic Expansion chuck

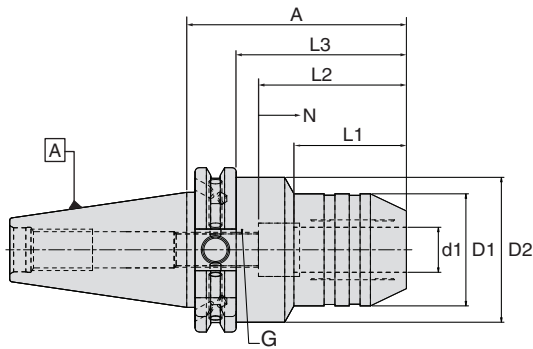

SK 40												
d (mm)	A (mm)	D1 (mm)	D2 (mm)	L1 (mm)	L2 (mm)	L3 (mm)	G	N	Kühlmittelzufuhr Coolant supply	N/W (Kg)	Bezeichnung Designation	Ident No.
6	80.5	22	26	27	30	61.4	M5X0.8	10	Form"AD/B"		WHEC/6-80.5/SK40	5055622
8	80.5	24	28	27	30	61.4	M6X1.0	10	Form"AD/B"		WHEC/8-80.5/SK40	5055623
10	80.5	26	30	32	32	61.4	M8X1.0	10	Form"AD/B"		WHEC/10-80.5/SK40	5055624
12	80.5	28	32	37	35	61.4	M10X1.0	10	Form"AD/B"		WHEC/12-80.5/SK40	5055625
14	80.5	33	36	37	35	61.4	M10X1.0	10	Form"AD/B"		WHEC/14-80.5/SK40	5055626
16	80.5	34	38	42	40	61.4	M12X1.0	10	Form"AD/B"		WHEC/16-80.5/SK40	5055627
18	80.5	38	41	42	40	61.4	M12X1.0	10	Form"AD/B"		WHEC/18-80.5/SK40	5055628
20	80.5	38	42	42	40	61.4	M16X1.0	10	Form"AD/B"		WHEC/20-80.5/SK40	5055629
25	80.5	46	50	48	45	61.4	M16X1.0	10	Form"AD/B"		WHEC/25-80.5/SK40	5055630
32	110.0	56	60	55	50	90.9	M16X1.0	10	Form"AD/B"		WHEC/32-110/SK40	5055631



SK 50												
d (mm)	D1 (mm)	D2 (mm)	A (mm)	L1 (mm)	L2 (mm)	L3 (mm)	G	N	Kühlmittelzufuhr Coolant supply	N/W (Kg)	Bezeichnung Designation	Ident No.
6	22	26	80.5	27	30	61.4	M5X0.8	10	Form"AD/B"		WHEC/6-80.5/SK50	5055632
8	24	28	80.5	27	30	61.4	M6X1.0	10	Form"AD/B"		WHEC/8-80.5/SK50	5055633
10	26	30	80.5	32	32	61.4	M8X1.0	10	Form"AD/B"		WHEC/10-80.5/SK50	5055635
12	28	32	80.5	37	35	61.4	M10X1.0	10	Form"AD/B"		WHEC/12-80.5/SK50	5055636
14	33	36	80.5	37	35	61.4	M10X1.0	10	Form"AD/B"		WHEC/14-80.5/SK50	5055637
16	34	38	80.5	42	40	61.4	M12X1.0	10	Form"AD/B"		WHEC/16-80.5/SK50	5055638
18	38	41	80.5	42	40	61.4	M12X1.0	10	Form"AD/B"		WHEC/18-80.5/SK50	5055639
20	38	42	80.5	42	40	61.4	M16X1.0	10	Form"AD/B"		WHEC/20-80.5/SK50	5055640
25	46	50	80.5	48	45	61.4	M16X1.0	10	Form"AD/B"		WHEC/25-80.5/SK50	5055641
32	56	60	110.0	55	50	90.9	M16X1.0	10	Form"AD/B"		WHEC/32-110/SK50	5055642

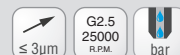

Ersatzteile und Zubehör / Spare Parts & Accessories:



NC Bohrfutter
NC Drill Chuck

BT MAS 403
ISO7388-2

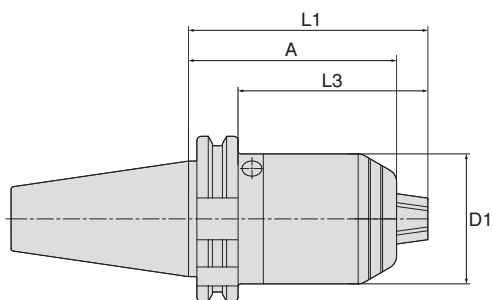

SK DIN 69871
ISO7388-1

SK 40									
D1 (mm)	A (mm)	L1 (mm)	L3 (mm)	Bereich Range	Kühlmittelzufuhr Coolant supply	N/W (Kg)	Bezeichnung Designation	Ident No.	
50	80	92	72.9	1-16	Form "AD"	1.55	WNDC/1-16-80/SK40	5055612	

SK 50									
D1 (mm)	A (mm)	L1 (mm)	L3 (mm)	Bereich Range	Kühlmittelzufuhr Coolant supply	N/W (Kg)	Bezeichnung Designation	Ident No.	
50	80	92	72.9	1-16	Form "AD"	3.32	WNDC/1-16-80/SK50	5055617	

- Hohe Rundlaufgenauigkeit | • Kompakte Bauweise
- Sichere Spannung durch selbsthemmendes Getriebe
- Für Rechts- und Linkslauf geeignet
- High run-out accuracy | • Compact design
- Secure clamping due to self-locking gear
- Suitable for clockwise and counter-clockwise operations

HSK DIN 69893

Zwischenhülsen für Morse-Kegel mit Anzugsgewinde DIN 6364 / 228A
Adaptor sleeves for Morse taper with thread DIN 6364 / 228A

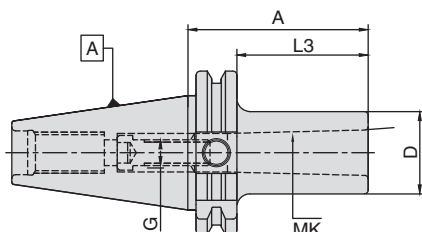

Zubehör
Accessories

SK 40									
MK	D (mm)	A (mm)	L3 (mm)	G	Kühlmittelzufuhr Coolant supply	N/W (Kg)	Bezeichnung Designation	Ident No.	
1	25	50	30.9	M6	-	1.0	WMTB/MT1-50/SK40	4600706	
2	32	50	30.9	M10	-	1.0	WMTB/MT2-50/SK40	4600707	
3	40	70	50.9	M12	-	1.1	WMTB/MT3-70/SK40	4600708	
4	48	95	75.9	M16	-	1.2	WMTB/MT4-95/SK40	4600709	

≤10 µm G6.3 8000 R.P.M.

SK 50									
MK	D (mm)	A (mm)	L3 (mm)	G	Kühlmittelzufuhr Coolant supply	N/W (Kg)	Bezeichnung Designation	Ident No.	
1	25	45	25.9	M6	-	2.7	WMTB/MT1-45/SK50	4601253	
2	32	60	40.9	M10	-	2.8	WMTB/MT2-60/SK50	4601254	
3	40	65	45.9	M12	-	2.9	WMTB/MT3-65/SK50	4601255	
4	48	95	75.9	M16	-	3.2	WMTB/MT4-95/SK50	4601256	
5	63	120	100.9	M20	-	4.0	WMTB/MT5-120/SK50	4601258	

≤10 µm G6.3 8000 R.P.M.

Ersatzteile und Zubehör / Spare Parts & Accessories: Pg.E5 Pg.D6 Pg.E5

- Datenträger-Borung (10 mm) Standard bei allen Grundhaltern
- Im Lieferumfang enthalten: eingebaute Innensechskantschraube
- Data carrier bore (10 mm) as std. for all holders
- Delivery includes: build-in draw screw

Ersatzteile
Spare Parts

Technische Spezifikationen
Technical Details

Zwischenhülsen für Morse-Kegel mit Austreibblappen DIN 6383
 Adaptor sleeves for Morse taper with tang to DIN 6383

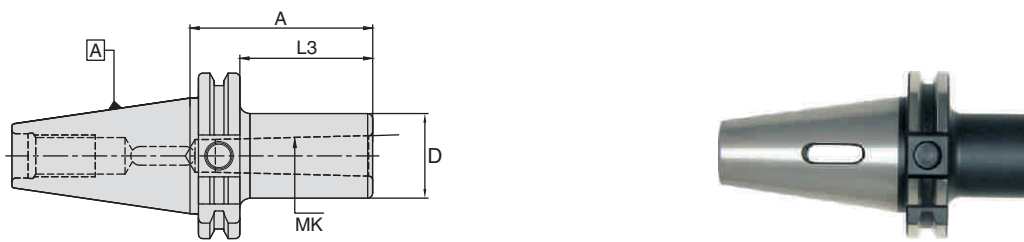

SK 40							
MK	D (mm)	A (mm)	L3 (mm)	Kühlmittelzufuhr Coolant supply	N/W (Kg)	Bezeichnung Designation	Ident No.
1	25	50	30.9	-	1.0	WMTA/MT1-50/SK40	4600808
2	32	50	30.9	-	1.0	WMTA/MT2-50/SK40	4600809
3	40	70	50.9	-	1.2	WMTA/MT3-70/SK40	4600810
4	48	95	75.9	-	2.3	WMTA/MT4-95/SK40	4600811
2	32	117	97.9	-	1.5	WMTA/MT2-117/SK40	4600703
3	40	133	113.9	-	1.7	WMTA/MT3-133/SK40	4600704
4	48	156	136.9	-	1.9	WMTA/MT4-156/SK40	4600705



SK 50							
MK	D (mm)	A (mm)	L3 (mm)	Kühlmittelzufuhr Coolant supply	N/W (Kg)	Bezeichnung Designation	Ident No.
1	25	45	25.9	-	3.5	WMTA/MT1-45/SK50	4601341
2	32	60	40.9	-	3.6	WMTA/MT2-60/SK50	4601342
3	40	65	45.9	-	3.6	WMTA/MT3-65/SK50	4601343
4	48	95	75.9	-	3.7	WMTA/MT4-95/SK50	4601344
5	70	105	85.9	-	3.8	WMTA/MT5-105/SK50	4601345
2	32	117	97.9	-	3.8	WMTA/MT2-117/SK50	4601249
3	40	137	117.9	-	3.8	WMTA/MT3-137/SK50	4601250
4	48	167	147.9	-	3.8	WMTA/MT4-167/SK50	4601251
5	70	195	175.9	-	3.8	WMTA/MT5-195/SK50	4601252



Ersatzteile und Zubehör / Spare Parts & Accessories: Pg.D6

• Datenträger-Bohrung (10 mm) Standard bei allen Grundhaltern

• Data carrier bore (10 mm) as standard for all holders

Aufnahme für Einschraubfräser
 Chuck for threaded milling heads

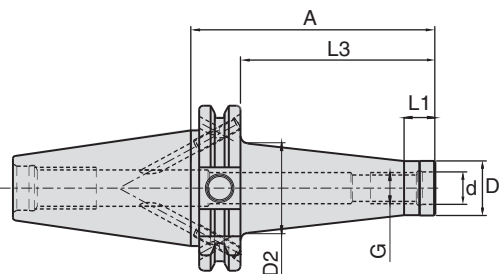

SK 40									
G	d (mm)	D1 (mm)	D2 (mm)	A (mm)	L1 (mm)	L3 (mm)	Kühlmittelezufuhr Coolant supply	Bezeichnung Designation	Ident No.
M6	6.5	10.0	13	44	12	24.9	Form"AD/B"	WTA/M6-44/SK40	5054973
M6	6.5	10.0	20	69	12	49.9	Form"AD/B"	WTA/M6-69/SK40	5054974
M6	6.5	10.0	23	94	12	74.9	Form"AD/B"	WTA/M6-94/SK40	5054975
M8	8.5	13.8	15	44	12	24.9	Form"AD/B"	WTA/M8-44/SK40	5054979
M8	8.5	13.8	23	69	12	49.9	Form"AD/B"	WTA/M8-69/SK40	5054980
M8	8.5	13.8	25	94	12	74.9	Form"AD/B"	WTA/M8-94/SK40	5054981
M8	8.5	13.8	30	119	12	99.9	Form"AD/B"	WTA/M8-119/SK40	5054982
M10	10.5	18.0	23	44	12	24.9	Form"AD/B"	WTA/M10-44/SK40	5054983
M10	10.5	18.0	25	69	12	49.9	Form"AD/B"	WTA/M10-69/SK40	5054985
M10	10.5	18.0	30	94	12	74.9	Form"AD/B"	WTA/M10-94/SK40	5054989
M10	10.5	18.0	35	119	12	99.9	Form"AD/B"	WTA/M10-119/SK40	5054991
M10	10.5	18.0	45	169	12	149.9	Form"AD/B"	WTA/M10-169/SK40	5054992
M12	12.5	21.0	24	44	12	24.9	Form"AD/B"	WTA/M12-44/SK40	5054993
M12	12.5	21.0	30	69	12	49.9	Form"AD/B"	WTA/M12-69/SK40	5054995
M12	12.5	21.0	35	94	12	74.9	Form"AD/B"	WTA/M12-94/SK40	5054996
M12	12.5	21.0	38	119	12	99.9	Form"AD/B"	WTA/M12-119/SK40	5054997
M12	12.5	21.0	48	169	12	149.9	Form"AD/B"	WTA/M12-169/SK40	5054998
M16	17.0	29.0	29	44	12	24.9	Form"AD/B"	WTA/M16-44/SK40	5054999
M16	17.0	29.0	34	69	12	49.9	Form"AD/B"	WTA/M16-69/SK40	5055001
M16	17.0	29.0	35	94	12	74.9	Form"AD/B"	WTA/M16-94/SK40	5055002
M16	17.0	29.0	40	119	12	99.9	Form"AD/B"	WTA/M16-119/SK40	5055003
M16	17.0	29.0	48	169	12	149.9	Form"AD/B"	WTA/M16-169/SK40	5054004

SK 50									
G	d (mm)	D1 (mm)	D2 (mm)	A (mm)	L1 (mm)	L3 (mm)	Kühlmittelezufuhr Coolant supply	Bezeichnung Designation	Ident No.
M8	8.5	13.8	23	69	12	49.9	Form"AD/B"	WTA/M8-69/SK50	5055005
M8	8.5	13.8	30	119	12	99.9	Form"AD/B"	WTA/M8-119/SK50	5055007
M8	8.5	13.8	45	169	12	149.9	Form"AD/B"	WTA/M8-169/SK50	5055011
M10	10.5	18.0	25	69	12	49.9	Form"AD/B"	WTA/M10-69/SK50	5055012
M10	10.5	18.0	35	119	12	99.9	Form"AD/B"	WTA/M10-119/SK50	5055013
M10	10.5	18.0	45	169	12	149.9	Form"AD/B"	WTA/M10-169/SK50	5055014
M12	12.5	21.0	30	69	12	49.9	Form"AD/B"	WTA/M12-69/SK50	5055016
M12	12.5	21.0	38	119	12	99.9	Form"AD/B"	WTA/M12-119/SK50	5055017
M12	12.5	21.0	52	169	12	149.9	Form"AD/B"	WTA/M12-169/SK50	5055018
M16	17.0	29.0	34	69	12	49.9	Form"AD/B"	WTA/M16-69/SK50	5055019
M16	17.0	29.0	40	119	12	99.9	Form"AD/B"	WTA/M16-119/SK50	5055022
M16	17.0	29.0	48	169	12	149.9	Form"AD/B"	WTA/M16-169/SK50	5055023

Ersatzteile und Zubehör / Spare Parts & Accessories: Pg.D6

Siehe Seite D12 für Einschraubfräser Verlängerung & Reduzierung
 Refer page. D12 for Threaded Arbor extensions & reductions.

BT MAS 403
 ISO7388-2

SK DIN 69871
 ISO7388-1

HSK DIN 69893

Zubehör
 Accessories

Ersatzteile
 Spare Parts

Technische Spezifikationen
 Technical Details

Aufsteckfräserdorne DIN 6358 mit Längs- und Quernut (Kombi)
Shell mill holder with DIN 6358 (Combi)

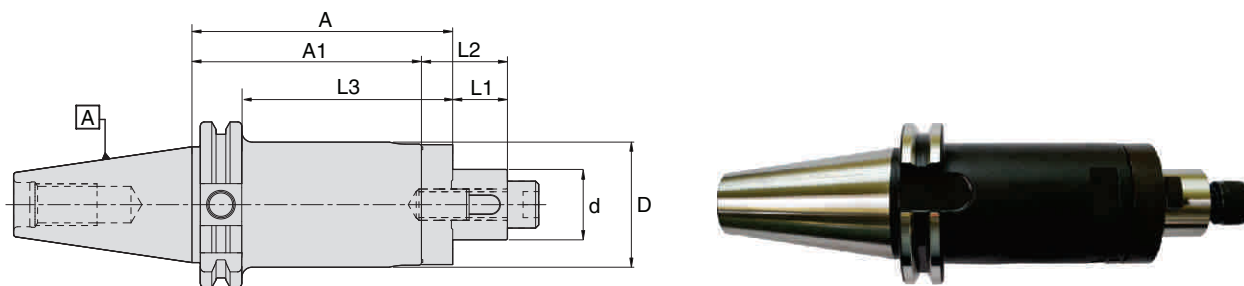

SK 40										
d (mm)	D (mm)	A (mm)	A1 (mm)	L1 (mm)	L2 (mm)	L3 (mm)	Kühlmittelzufuhr Coolant supply	N/W (Kg)	Bezeichnung Designation	Ident No.
16	32	55	45	27	17	36	-	1.1	WFSH/16-55/SK40	4600812
22	40	55	43	31	19	36	-	1.3	WFSH/22-55/SK40	4600814
27	48	55	43	33	21	36	-	1.5	WFSH/27-55/SK40	4600816
32	58	60	46	38	24	41	-	1.8	WFSH/32-60/SK40	4600818
40	70	60	46	41	27	41	-	2.1	WFSH/40-60/SK40	4600820
16	32	100	90	27	17	81	-	1.4	WFSH/16-100/SK40	4600813
22	40	100	88	31	19	81	-	1.8	WFSH/22-100/SK40	4600815
27	48	100	88	33	21	81	-	2.2	WFSH/27-100/SK40	4600817
32	58	100	86	38	24	81	-	2.6	WFSH/32-100/SK40	4600819
40	70	100	86	41	27	81	-	2.8	WFSH/40-100/SK40 *	4600821



SK 50										
d (mm)	D (mm)	A (mm)	A1 (mm)	L1 (mm)	L2 (mm)	L3 (mm)	Kühlmittelzufuhr Coolant supply	N/W (Kg)	Bezeichnung Designation	Ident No.
16	32	55	45	27	17	36	-	2.9	WFSH/16-55/SK50	4601346
22	40	55	43	31	19	36	-	3.1	WFSH/22-55/SK50	4601348
27	48	55	43	33	21	36	-	3.3	WFSH/27-55/SK50	4601350
32	58	55	41	38	24	36	-	3.5	WFSH/32-55/SK50	4601352
40	70	55	41	41	27	36	-	3.7	WFSH/40-55/SK50	4601354
50	90	70	54	46	30	51	-	4.3	WFSH/50-70/SK50	5054972
16	32	100	90	27	17	81	-	3.4	WFSH/16-100/SK50	4601347
22	40	100	88	31	19	81	-	3.6	WFSH/22-100/SK50	4601349
27	48	100	88	33	21	81	-	3.9	WFSH/27-100/SK50	4601351
32	58	100	86	38	24	81	-	4.2	WFSH/32-100/SK50	4601353
40	70	100	86	41	27	81	-	4.9	WFSH/40-100/SK50 *	4601355



Ersatzteile und Zubehör / Spare Parts & Accessories:



- Datenträger-Bohrung (10 mm) Standard bei allen Grundhaltern
- Im Lieferumfang enthalten: Passfeder, Mitnehmerring, Fräseranzugsschraube und Spannschrauben (DIN 912)
- Spannschrauben bitte separat bestellen (DIN 6367)
- * Im Lieferumfang enthalten: Spannschrauben (DIN 912 & DIN 6367)

- Data carrier bore (10 mm) as standard for all holders
- Delivery includes: Parallel key, drive ring, clamping screw and locking screw (DIN 912)
- Please order locking screw (DIN 6367) separately
- * Delivery includes: Locking screw (both DIN 912 & DIN 6367)

Aufnahmedorn mit Innenzentrierung DIN 6357 mit vergrößertem Bunddurchmesser
Shell mill holder DIN 6357 for cutters with drive key

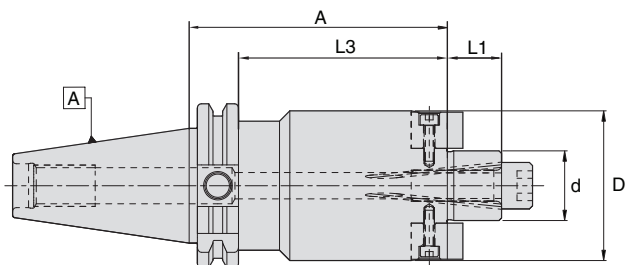

SK 40								
d (mm)	D (mm)	A (mm)	L1 (mm)	L3 (mm)	Kühlmittelzufuhr Coolant supply	N/W (Kg)	Bezeichnung Designation	Ident No.
16	38	35	17	15.9	Form"AD/B"	1.0	WSMH/16-35/SK40	4600822
22	48	35	19	15.9	Form"AD/B"	1.0	WSMH/22-35/SK40	4600823
27	50	40	21	20.9	Form"AD/B"	1.1	WSMH/27-40/SK40	4600824
32	78	50	24	30.9	Form"AD/B"	1.3	WSMH/32-50/SK40	4600825
40	88	50	27	30.9	Form"AD/B"	1.6	WSMH/40-50/SK40+*	4600826
16	38	100	17	80.9	Form"AD/B"	1.8	WSMH/16-100/SK40	5055095
22	48	100	19	80.9	Form"AD/B"	2.1	WSMH/22-100/SK40	5055102
27	58	100	21	80.9	Form"AD/B"	2.6	WSMH/27-100/SK40	5055104
32	78	100	24	80.9	Form"AD/B"	3.6	WSMH/32-100/SK40	5055105
40	88	100	27	80.9	Form"AD/B"	4.3	WSMH/40-100/SK40+*	5055106
16	38	160	17	140.9	Form"AD/B"	2.1	WSMH/16-160/SK40	5055107
22	48	160	19	140.9	Form"AD/B"	2.7	WSMH/22-160/SK40	5055108
27	58	160	21	140.9	Form"AD/B"	3.7	WSMH/27-160/SK40	5055109
32	78	160	24	140.9	Form"AD/B"	5.8	WSMH/32-160/SK40	5055110
40	88	160	27	140.9	Form"AD/B"	6.6	WSMH/40-160/SK40+*	5055111

SK 50								
d (mm)	D (mm)	A (mm)	L1 (mm)	L3 (mm)	Kühlmittelzufuhr Coolant supply	N/W (Kg)	Bezeichnung Designation	Ident No.
16	38	44	17	24.9	Form"AD/B"	2.8	WSMH/16-44/SK50	5055112
22	48	44	19	24.9	Form"AD/B"	3.0	WSMH/22-44/SK50	4601356
27	58	44	21	24.9	Form"AD/B"	3.2	WSMH/27-44/SK50	4601357
32	78	40	24	20.9	Form"AD/B"	4.0	WSMH/32-40/SK50	4601358
40	88	50	27	30.9	Form"AD/B"	4.2	WSMH/40-50/SK50+*	4601359
60	129	70	40	50.9	-	4.8	WSMH/60-70/SK50+	4601360
16	38	100	17	80.9	Form"AD/B"	3.6	WSMH/16-100/SK50	5055123
22	48	100	19	80.9	Form"AD/B"	4.0	WSMH/22-100/SK50	5055125
27	58	100	21	80.9	Form"AD/B"	4.4	WSMH/27-100/SK50	5055126
32	78	100	24	80.9	Form"AD/B"	5.2	WSMH/32-100/SK50	5055127
40	88	100	27	80.9	Form"AD/B"	6.0	WSMH/40-100/SK50+*	5055128
16	38	160	17	140.9	Form"AD/B"	3.9	WSMH/16-160/SK50	5055130
22	48	160	19	140.9	Form"AD/B"	4.2	WSMH/22-160/SK50	5055131
27	58	160	21	140.9	Form"AD/B"	5.3	WSMH/27-160/SK50	5055132
32	78	160	24	140.9	Form"AD/B"	7.2	WSMH/32-160/SK50	5055133
40	88	160	27	140.9	Form"AD/B"	8.8	WSMH/40-160/SK50+*	5055134

Ersatzteile und Zubehör / Spare Parts & Accessories: Pg.D8 Pg.E3 Pg.E4 Pg.D6 Pg.E4

- Datenträger-Bohrung (10 mm) Standard bei allen Grundhaltern
 - Kühlbohrung an der Stirnseite Standard bei allen Grundhaltern
 - ✦ ID = Ø 40, D = Ø 60 Mit 4 zusätzlichen Gewindebohrungen nach DIN 2079
 - Im Lieferumfang enthalten: Mitnehmersteine, Fräseranzugsschraube und Spannschrauben (DIN 912)
 - Spannschrauben bitte separat bestellen (DIN6367)
 - * Im Lieferumfang enthalten: Spannschrauben (DIN 912 & DIN 6367)
- Data carrier bore (10 mm) as standard for all holders
 - Coolant bore on the pilot face (holder with Form"AD/B") as standard for all holders
 - ✦ ID = Ø 40, D = Ø 60 with additional 4 screw holes to DIN 2079
 - Delivery includes: Drive keys, clamping screw and locking screw (DIN 912)
 - Please order locking screw (DIN 6367) separately
 - * Delivery includes: Locking screw (both DIN 912 & DIN 6367)

Zwischenhülsen
Reduction Sleeves

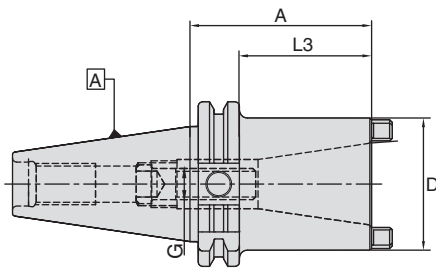

SK 40									
Innenkegelgröße Inside Taper	D (mm)	A (mm)	L3 (mm)	G	Kühlmittelzufuhr Coolant supply	N/W (Kg)	Bezeichnung Designation	Ident No.	
SK 30	51	50	30.9	M12	-	1.2	SK40-SK30-50	4600711	
SK 40	63	100	80.9	M16	-	1.7	SK40-SK40-100	4600712	

SK 50									
Innenkegelgröße Inside Taper	D (mm)	A (mm)	L3 (mm)	G	Kühlmittelzufuhr Coolant supply	N/W (Kg)	Bezeichnung Designation	Ident No.	
SK 40	70	80	60.9	M16	-	3.6	SK50-SK40-80	4601260	
SK 50	100	120	100.9	M24	-	6.0	SK50-SK50-120	4601261	

Ersatzteile und Zubehör / Spare Parts & Accessories: Pg.E7 Pg.D7 Pg.E7

- Datenträger-Bohrung (10mm) Standard bei allen Grundhaltern
- Im Lieferumfang enthalten: eingebaute Innensechskantschraube
- Data carrier bore (10 mm) as standard for all holders
- Delivery includes: built-in draw screw

Bohrstangenrohlinge
Boring bar blanks

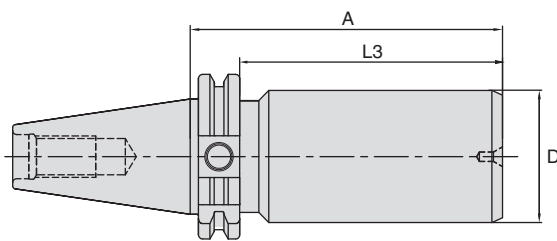

SK 40							
D (mm)	A (mm)	L3 (mm)	Kühlmittelzufuhr Coolant supply	N/W (Kg)	Bezeichnung Designation	Ident No.	
63	250	231	"AD/B"	6.5	WBBB/63-250/SK40	4600725	

SK 50							
D (mm)	A (mm)	L3 (mm)	Kühlmittelzufuhr Coolant supply	N/W (Kg)	Bezeichnung Designation	Ident No.	
63.5	300	281	"AD/B"	9.5	WBBB/63.5-300/SK50	4601272	

- Im Lieferumfang enthalten: Steilkegel und Bund gehärtet und geschliffen, Schaft weich zur weiteren Bearbeitung
- Delivery includes: Steep taper and flange hardened, body left soft

Kontrolldorn
Test Arbor

BT MAS 403
ISO7388-2

SK DIN 69871
ISO7388-1

HSK DIN 69893

Zubehör
Accessories

Ersatzteile
Spare Parts

Technische Spezifikationen
Technical Details

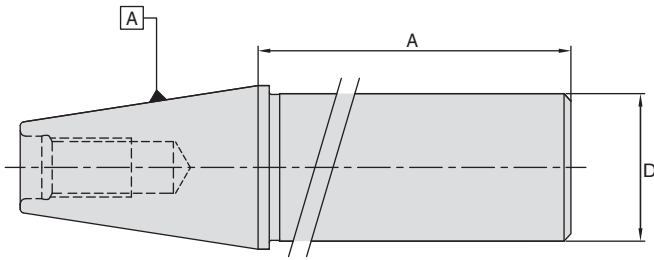

SK 40 ↗ ≤ 2µm					
D (mm)	A (mm)	Kühlmittelezufuhr Coolant supply	N/W (Kg)	Bezeichnung Designation	Ident No.
40	330	-	3.0	WTMM/40-330/SK40	5056226

SK 50 ↗ ≤ 2µm					
D (mm)	A (mm)	Kühlmittelezufuhr Coolant supply	N/W (Kg)	Bezeichnung Designation	Ident No.
50	330	-	6.3	WTMM/50-330/BT50	5056227

- Diese Dorne haben keinen Bund
- Kontrolldorne werden im Holzkasten geliefert.
- These gauge are without flange
- Delivered in wooden box

DIN 69893 (HSK-A) Werkzeugaufnahmen
 DIN 69893 (HSK-A) Tool Holders

Spannzangenfutter ER Collet chuck ER	C2-C3
Super collet Spannzangenfutter Super collet chuck	C4
Fräseraufnahmen (Weldon) End mill holder (Weldon)	C5-C8
Fräseraufnahmen (Whistle Notch) End mill holder (Whistle Notch)	C9
Hochleistungsfräterspannfutter Hi-power milling chuck	C10
Schlanke Hochleistungsfräterspannfutter Slim Hi-power milling chuck	C11
Hydrodehnspannfutter Hydraulic expansion chucks	C12
NC Bohrfutter NC Drill chuck	C13
Aufnahmen für Morse-Kegel mit Anzugsgewinde Morse taper holder with thread	C14
Aufnahmen für Morse-Kegel mit Austreibklappen Morse taper holder with tang	C15
Aufnahmen für Einschraubfräser Chuck for threaded milling heads	C16
Kombi-Aufsteckfräserdorn Combi shell mill holder	C17
Messerkopf-Aufnahme Shell mill holder	C18
Bohrstangenrohlinge Boring bar blanks	C19
Pendelhalter (PN / HSK) Floating chuck (PN / HSK)	C20
Kontrolldorn Test Arbor	C21

Spannzangenfutter Typ ER für Spannzangen DIN 6499
Collet chuck type ER for collets to DIN 6499

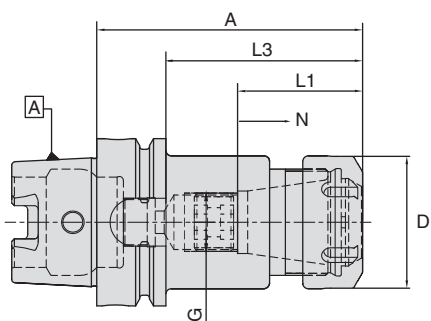

HSK-A32											≤ 3 μm	G2.5 15000 R.P.M.	bar
Spannzange Collet Type	Bereich Range	D (mm)	A (mm)	L1 (mm)	L3 (mm)	G	N	Kühlmittelzufuhr Coolant supply	N/W (Kg)	Bezeichnung Designation	Ident No.		
ER16M	1-10	22	65	34	45	M10	12	Form "AD"	0.3	WCCH/ER16M-65/HSK-A32	9202350		
ER20M	1-13	28	70	38	50	M12	12	Form "AD"	0.4	WCCH/ER20M-70/HSK-A32	5068528		
ER25M	2-16	35	70	41	50	M16	12	Form "AD"	0.4	WCCH/ER25M-70/HSK-A32	9202351		

HSK-A40											≤ 3 μm	G2.5 15000 R.P.M.	bar
Spannzange Collet Type	Bereich Range	D (mm)	A (mm)	L1 (mm)	L3 (mm)	G	N	Kühlmittelzufuhr Coolant supply	N/W (Kg)	Bezeichnung Designation	Ident No.		
ER16M	1-10	22	70	34	50	M10	12	Form "AD"	0.4	WCCH/ER16M-70/HSK-A40	9202352		
ER20	1-13	34	80	38	60	M12	12	Form "AD"	0.5	WCCH/ER20-80/HSK-A40	5068534		
ER25	2-16	42	80	41	60	M16	12	Form "AD"	0.5	WCCH/ER25-80/HSK-A40	5068535		
ER32	2-20	50	100	47	80	M22X1.5	12	Form "AD"	0.7	WCCH/ER32-100/HSK-A40	9202354		
ER16M	1-10	22	120	34	100	M10	12	Form "AD"	0.6	WCCH/ER16M-120/HSK-A40	9202355		
ER20M	1-13	28	120	38	100	M12	12	Form "AD"	0.5	WCCH/ER20M-120/HSK-A40	5068538		
ER25M	2-16	35	120	41	100	M16	12	Form "AD"	0.75	WCCH/ER25M-120/HSK-A40	9202356		

HSK-A50											≤ 3 μm	G2.5 15000 R.P.M.	bar
Spannzange Collet Type	Bereich Range	D (mm)	A (mm)	L1 (mm)	L3 (mm)	G	N	Kühlmittelzufuhr Coolant supply	N/W (Kg)	Bezeichnung Designation	Ident No.		
ER16M	1-10	22	80	34	54	M10	12	Form "AD"	0.9	WCCH/ER16M-80/HSK-A50	9202357		
ER20	1-13	34	95	38	69	M12	12	Form "AD"	1.00	WCCH/ER20-95/HSK-A50	5068540		
ER25	2-16	42	95	41	69	M16	12	Form "AD"	1.05	WCCH/ER25-95/HSK-A50	9202358		
ER32	2-20	50	100	47	74	M22X1.5	12	Form "AD"	0.85	WCCH/ER32-100/HSK-A50	5056308		

Ersatzteile und Zubehör / Spare Parts & Accessories: Pg.D2 Pg.D4 Pg.D3 Pg.D8

- Kühlmittelrohr bitte separat bestellen (Siehe Seite D8)
- Im Lieferumfang enthalten: Spannmutter (gewuchtet) und Einstellschraube
- Please order coolant tube separately (See page D8)
- Delivery includes: Clamping nut (balanced)

BT MAS 403
ISO7388-2

SK DIN 69871
ISO7388-1

HSK DIN 69893

Zubehör
Accessories

Ersatzteile
Spare Parts

Technische Spezifikationen
Technical Details

Spannzangenfutter Typ ER für Spannzangen DIN 6499

Collet chuck type ER for collets to DIN 6499

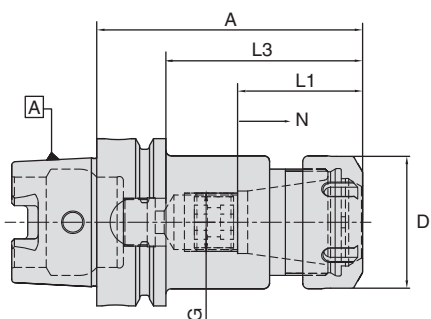

HSK-A63									
Spannzange Collet Type	Bereich Range	D (mm)	A (mm)	G	N	Kühlmittelezufuhr Coolant supply	N/W (Kg)	Bezeichnung Designation	Ident No.
ER16M	1-10	22	100	M10	12	Form "AD"	1.3	WCCH/ER16M-100/HSK-A63	5055257
ER20	1-13	34	100	M12	12	Form "AD"	1.3	WCCH/ER20-100/HSK-A63	5055258
ER25	2-16	42	100	M16	12	Form "AD"	1.7	WCCH/ER25-100/HSK-A63	4601696
ER32	2-20	50	100	M22X1.5	12	Form "AD"	2.3	WCCH/ER32-100/HSK-A63	4601698
ER40	3-26	63	120	M22X1.5	12	Form "AD"	2.7	WCCH/ER40-120/HSK-A63	4601700

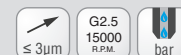

HSK-A63									
Spannzange Collet Type	Bereich Range	D (mm)	A (mm)	G	N	Kühlmittelezufuhr Coolant supply	N/W (Kg)	Bezeichnung Designation	Ident No.
ER16M	1-10	22	160	M10	12	Form "AD"	1.2	WCCH/ER16M-160/HSK-A63*	5055261
ER20M	1-13	28	160	M12	12	Form "AD"	1.2	WCCH/ER20M-160/HSK-A63	5055262
ER25M	2-16	35	160	M16	12	Form "AD"	1.7	WCCH/ER25M-160/HSK-A63*	5055263
ER32	2-20	50	160	M22X1.5	12	Form "AD"	2.3	WCCH/ER32-160/HSK-A63	4601699
ER40	3-26	63	160	M22X1.5	12	Form "AD"	2.8	WCCH/ER40-160/HSK-A63	4601701

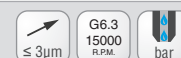

HSK-A100									
Spannzange Collet Type	Bereich Range	D (mm)	A (mm)	G	N	Kühlmittelezufuhr Coolant supply	N/W (Kg)	Bezeichnung Designation	Ident No.
ER20	1-13	34	100	M12	12	Form "AD"	2.5	WCCH/ER20-100/HSK-A100	5055502
ER25	2-16	42	100	M16	12	Form "AD"	2.7	WCCH/ER25-100/HSK-A100	4601611
ER32	2-20	50	100	M22X1.5	12	Form "AD"	2.9	WCCH/ER32-100/HSK-A100	4601612
ER40	3-26	63	120	M22X1.5	12	Form "AD"	2.3	WCCH/ER40-120/HSK-A100	4601613
ER20	1-13	34	160	M12	12	Form "AD"	2.5	WCCH/ER20-160/HSK-A100	5055504
ER25	2-16	42	160	M16	12	Form "AD"	3.2	WCCH/ER25-160/HSK-A100	5055506
ER32	2-20	50	160	M22X1.5	12	Form "AD"	3.5	WCCH/ER32-160/HSK-A100	5055507
ER40	3-26	63	160	M22X1.5	12	Form "AD"	3.8	WCCH/ER40-160/HSK-A100	5055508

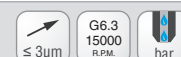

Ersatzteile und Zubehör / Spare Parts & Accessories:



Pg.D2



Pg.D4



Pg.D3



Pg.D8

* Gemäß Kegelausführung

- Kühlmittelrohr bitte separat bestellen (Siehe Seite D8)
- Im Lieferumfang enthalten: Spannmutter (gewuchtet) und Einstellschraube

* As per taper design

- Please order coolant tube separately (See page D8)
- Delivery includes: Clamping nut (balanced) & adjusting screw

Super collet Spannzangenfutter
Super collet chuck

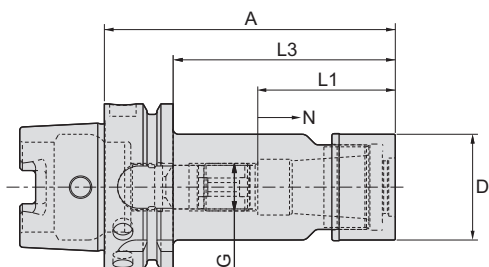

HSK-A50											
Spannzange Collet Type	Bereich Range	D (mm)	A (mm)	L1 (mm)	L3 (mm)	G (mm)	N (mm)	Kühlmittelezufuhr Coolant supply	N/W (Kg)	Bezeichnung Designation	Ident No.
SC06	2-6	19.5	80	31.5	54	M8	12	Form "AD"	0,7	WSCH/SCF06-80/HSK-A50	5102129
SC10	2-10	27.1	100	35.0	74	M12	12	Form "AD"	0,8	WSCH/SCF10-100/HSK-A50	5102130
SC13	3-13	33.0	100	43.0	74	M15	16	Form "AD"	0,8	WSCH/SCF13-100/HSK-A50	5102131

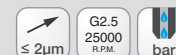

HSK-A63											
Spannzange Collet Type	Bereich Range	D (mm)	A (mm)	L1 (mm)	L3 (mm)	G (mm)	N (mm)	Kühlmittelezufuhr Coolant supply	N/W (Kg)	Bezeichnung Designation	Ident No.
SC06	2-6	19.5	100	31.5	74.0	M8	12	Form "AD"	0,9	WSCH/SCF06-100/HSK-A63	5102132
SC06	2-6	19.5	120	31.5	94.0	M8	12	Form "AD"	1,0	WSCH/SCF06-120/HSK-A63	5102133
SC06	2-6	19.5	150	31.5	124.0	M8	12	Form "AD"	1,0	WSCH/SCF06-150/HSK-A63	5102134
SC10	2-10	27.1	105	35	79.0	M12	12	Form "AD"	1,0	WSCH/SCF10-105/HSK-A63	5102135
SC10	2-10	27.1	120	35	94.0	M12	12	Form "AD"	1,1	WSCH/SCF10-120/HSK-A63	5102136
SC10	2-10	27.1	150	35	124.0	M12	12	Form "AD"	1,2	WSCH/SCF10-150/HSK-A63	5102137
SC13	3-13	33.0	120	43	94.0	M15	16	Form "AD"	1,2	WSCH/SCF13-120/HSK-A63	5102138
SC13	3-13	33.0	150	43	124.0	M15	16	Form "AD"	1,3	WSCH/SCF13-150/HSK-A63	5102141
SC16	4-16	40.0	120	52	94.0	M18	16	Form "AD"	1,4	WSCH/SCF16-120/HSK-A63	5102142
SC16	4-16	40.0	150	52	124.0	M18	16	Form "AD"	1,7	WSCH/SCF16-150/HSK-A63	5102143
SC20	6-20	48.0	120	59.5	94.0	M22	16	Form "AD"	1,7	WSCH/SCF20-120/HSK-A63	5102144
SC20	6-20	48.0	150	59.5	124.0	M22	16	Form "AD"	2,1	WSCH/SCF20-150/HSK-A63	5102145
SC25	6-25	55.0	135	63.5	109.0	M28	20	Form "AD"	2,1	WSCH/SCF25-135/HSK-A63	5102146

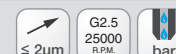

HSK-A100											
Spannzange Collet Type	Bereich Range	D (mm)	A (mm)	L1 (mm)	L3 (mm)	G (mm)	N (mm)	Kühlmittelezufuhr Coolant supply	N/W (Kg)	Bezeichnung Designation	Ident No.
SC06	2-6	19.5	105	31.5	76.0	M8	12	Form "AD"	2,3	WSCH/SCF06-105/HSK-A100	5102188
SC10	2-10	27.1	105	35	76.0	M12	12	Form "AD"	2,4	WSCH/SCF10-105/HSK-A100	5102189
SC10	2-10	27.1	120	35	91.0	M12	12	Form "AD"	2,5	WSCH/SCF10-120/HSK-A100	5102190
SC10	2-10	27.1	150	35	121.0	M12	12	Form "AD"	2,6	WSCH/SCF10-150/HSK-A100	5102191
SC13	3-13	33.0	120	43	91.0	M15	16	Form "AD"	2,6	WSCH/SCF13-120/HSK-A100	5102192
SC13	3-13	33.0	150	43	121.0	M15	16	Form "AD"	2,8	WSCH/SCF13-150/HSK-A100	5102193
SC16	4-16	40.0	120	52	91.0	M18	16	Form "AD"	2,6	WSCH/SCF16-120/HSK-A100	5102194
SC16	4-16	40.0	150	52	121.0	M18	16	Form "AD"	3,0	WSCH/SCF16-150/HSK-A100	5102195
SC20	6-20	48.0	120	59.5	91.0	M22	16	Form "AD"	3,1	WSCH/SCF20-120/HSK-A100	5102196
SC20	6-20	48.0	150	59.5	121.0	M22	16	Form "AD"	3,5	WSCH/SCF20-150/HSK-A100	5102197
SC25	6-25	55.0	145	63.5	116.0	M28	20	Form "AD"	3,6	WSCH/SCF25-145/HSK-A100	5102198

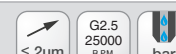

Ersatzteile und Zubehör / Spare Parts & Accessories: Pg.D13 Pg.D15 Pg.D14 Pg.D8

• Im Lieferumfang enthalten: Spannmutter (gewuchtet) und Einstellschraube • Delivery includes: Clamping nut (friction type), Adjusting screw

Fräseraufnahmen (Weldon) - für Zylinderschäfte gemäß DIN 1835 B
 End mill holder (Weldon) - For cylindrical shanks according to DIN 1835 B

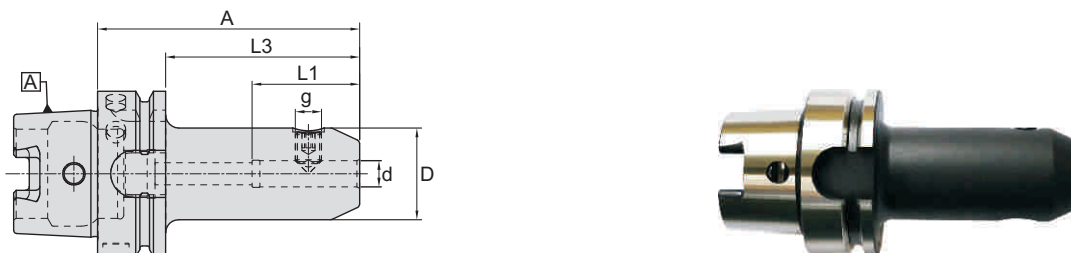

HSK-A32									
d (mm)	D (mm)	A (mm)	L1 (mm)	L3 (mm)	g	Kühlmittelezufuhr Coolant supply	N/W (Kg)	Bezeichnung Designation	Ident No.
06	25	60	37	40	M6	Form "AD"	0.3	WSLH/06-60/HSK-A32	9202366
08	28	60	37	40	M8	Form "AD"	0.3	WSLH/08-60/HSK-A32	9202367
10	35	65	41	45	M10	Form "AD"	0.4	WSLH/10-65/HSK-A32	9202368
12	42	75	46	55	M12	Form "AD"	0.6	WSLH/12-75/HSK-A32	9202369
16	48	75	49	55	M14	Form "AD"	0.7	WSLH/16-75/HSK-A32	9202370

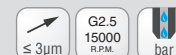

HSK-A40									
d (mm)	D (mm)	A (mm)	L1 (mm)	L3 (mm)	g	Kühlmittelezufuhr Coolant supply	N/W (Kg)	Bezeichnung Designation	Ident No.
06	25	60	37	40	M6	Form "AD"	0.4	WSLH/06-60/HSK-A40	9202371
08	28	60	37	40	M8	Form "AD"	0.4	WSLH/08-60/HSK-A40	9202372
10	34	65	41	45	M10	Form "AD"	0.5	WSLH/10-65/HSK-A40	9202373
12	42	70	46	50	M12	Form "AD"	0.6	WSLH/12-70/HSK-A40	9202374
16	48	80	49	60	M14	Form "AD"	0.8	WSLH/16-80/HSK-A40	9202375
20	52	80	51	60	M16	Form "AD"	0.8	WSLH/20-80/HSK-A40	9202376

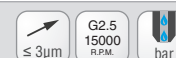

HSK-A50									
d (mm)	D (mm)	A (mm)	L1 (mm)	L3 (mm)	g	Kühlmittelezufuhr Coolant supply	N/W (Kg)	Bezeichnung Designation	Ident No.
06	25	65	39	37	M6	Form "AD"	0.6	WSLH/06-65/HSK-A50	9202377
08	28	65	39	37	M8	Form "AD"	0.6	WSLH/08-65/HSK-A50	9202378
10	35	65	39	41	M10	Form "AD"	0.7	WSLH/10-65/HSK-A50	9202379
12	42	80	54	46	M12	Form "AD"	0.7	WSLH/12-80/HSK-A50	9202380
16	48	80	54	49	M14	Form "AD"	0.7	WSLH/16-80/HSK-A50	9202381
20	52	80	54	51	M16	Form "AD"	0.1	WSLH/20-80/HSK-A50	9202382
25	62.5	105	79	59	M18	Form "AD"	1.2	WSLH/25-105/HSK-A50 **	9202383
32	72	120	94	63	M20	Form "AD"	1.3	WSLH/32-120/HSK-A50 **	9202384

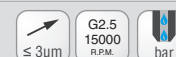

Ersatzteile und Zubehör / Spare Parts & Accessories:



Pg.E2



Pg.D8

- Bohrungstoleranz H4
- Kühlmittelrohr bitte separat bestellen (Siehe Seite D8)
- Im Lieferumfang enthalten: Spannschraube
- ** 2 Spannschrauben für ID Größe = 25 / 32 / 40

- Bore tolerance H4
- Please order coolant tube separately (See page D8)
- Delivery includes: Locking screw
- ** 2 locking screws for ID size = 25 / 32 / 40

Fräseraufnahmen (Weldon) - für Zylinderschäfte gemäß DIN 1835 B
 End mill holder (Weldon) - For cylindrical shanks according to DIN 1835 B

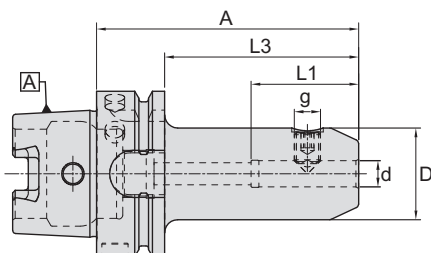

HSK-A63									
d (mm)	D (mm)	A (mm)	L1 (mm)	L3 (mm)	g	Kühlmittelezufuhr Coolant supply	N/W (Kg)	Bezeichnung Designation	Ident No.
06	25	65	37	39	M6	Form "AD"	1.0	WSLH/06-65/HSK-A63	4601702
08	28	65	37	39	M8	Form "AD"	1.0	WSLH/08-65/HSK-A63	4601705
10	35	65	41	39	M10	Form "AD"	1.0	WSLH/10-65/HSK-A63	4601708
12	42	80	46	54	M12	Form "AD"	1.4	WSLH/12-80/HSK-A63	4601711
14	44	80	46	54	M12	Form "AD"	1.4	WSLH/14-80/HSK-A63	4601715
16	48	80	49	54	M14	Form "AD"	1.4	WSLH/16-80/HSK-A63	4601719
18	50	80	49	54	M14	Form "AD"	1.7	WSLH/18-80/HSK-A63	4601723
20	52	80	51	54	M16	Form "AD"	1.7	WSLH/20-80/HSK-A63	4601727
06	25	100	37	74	M6	Form "AD"	1.2	WSLH/06-100/HSK-A63	4601703
08	28	100	37	74	M8	Form "AD"	1.2	WSLH/08-100/HSK-A63	4601706
10	35	100	41	74	M10	Form "AD"	1.2	WSLH/10-100/HSK-A63	4601709
12	42	100	46	74	M12	Form "AD"	1.5	WSLH/12-100/HSK-A63	5056629
16	48	100	49	74	M14	Form "AD"	1.7	WSLH/16-100/HSK-A63	5056632
20	52	100	51	74	M16	Form "AD"	1.9	WSLH/20-100/HSK-A63	5065495
25	62.5	110	59	84	M18	Form "AD"	2.5	WSLH/25-110/HSK-A63 **	4601730
32	72	110	63	84	M20	Form "AD"	2.5	WSLH/32-110/HSK-A63 **	4601732
40	80	125	73	99	M20	Form "AD"	3.2	WSLH/40-125/HSK-A63 **	4601734

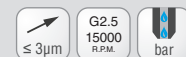

HSK-A63									
d (mm)	D (mm)	A (mm)	L1 (mm)	L3 (mm)	g	Kühlmittelezufuhr Coolant supply	N/W (Kg)	Bezeichnung Designation	Ident No.
06	25	160	37	134	M6	Form "AD"	1.4	WSLH/06-160/HSK-A63	5056636
08	28	160	37	134	M8	Form "AD"	1.5	WSLH/08-160/HSK-A63	5056638
10	35	160	41	134	M10	Form "AD"	1.8	WSLH/10-160/HSK-A63	5056640
12	42	160	46	134	M12	Form "AD"	1.8	WSLH/12-160/HSK-A63	5056642
16	48	160	49	134	M14	Form "AD"	1.8	WSLH/16-160/HSK-A63	5056643
20	52	160	51	134	M16	Form "AD"	1.7	WSLH/20-160/HSK-A63	5056645

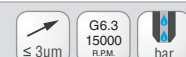

Ersatzteile und Zubehör / Spare Parts & Accessories:



Pg.E2



Pg.D8

- Bohrungstoleranz H4
- Kühlmittelrohr bitte separat bestellen (Siehe Seite D8)
- Im Lieferumfang enthalten: Spanschraube
- ** 2 Spanschrauben für ID Größe = 25 / 32 / 40

- Bore tolerance H4
- Please order coolant tube separately (See page D8)
- Delivery includes: Locking screw
- ** 2 locking screws for ID size = 25 / 32 / 40

Fräseraufnahmen (Weldon) - für Zylinderschäfte gemäß DIN 1835 B
 End mill holder (Weldon) - For cylindrical shanks according to DIN 1835 B

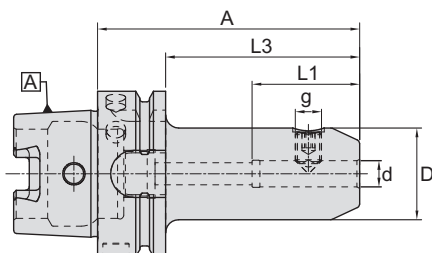

HSK-A100									
d (mm)	D (mm)	A (mm)	L1 (mm)	L3 (mm)	g	Kühlmittelzufuhr Coolant supply	N/W (Kg)	Bezeichnung Designation	Ident No.
06	25	80	37	51	M6	Form "AD"	2.5	WSLH/06-80/HSK-A100	4601614
08	28	80	37	51	M8	Form "AD"	2.4	WSLH/08-80/HSK-A100	4601616
10	35	80	41	51	M10	Form "AD"	2.5	WSLH/10-80/HSK-A100	4601618
12	42	80	46	51	M12	Form "AD"	2.7	WSLH/12-80/HSK-A100	4601620
14	44	80	46	51	M12	Form "AD"	2.7	WSLH/14-80/HSK-A100	4601622
16	48	100	49	71	M14	Form "AD"	2.8	WSLH/16-100/HSK-A100	4601624
18	50	100	49	71	M14	Form "AD"	2.9	WSLH/18-100/HSK-A100	4601626
20	52	100	51	71	M16	Form "AD"	3.2	WSLH/20-100/HSK-A100	4601628
25	65	100	59	71	M18	Form "AD"	3.7	WSLH/25-100/HSK-A100 **	4601630
32	72	100	63	71	M20	Form "AD"	4.0	WSLH/32-100/HSK-A100 **	4601632
40	80	105	73	76	M20	Form "AD"	4.7	WSLH/40-105/HSK-A100 **	4601634

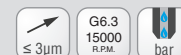

HSK-A100									
d (mm)	D (mm)	A (mm)	L1 (mm)	L3 (mm)	g	Kühlmittelzufuhr Coolant supply	N/W (Kg)	Bezeichnung Designation	Ident No.
06	25	160	37	131	M6	Form "AD"	2.7	WSLH/06-160/HSK-A100	5056735
08	28	160	37	131	M8	Form "AD"	2.9	WSLH/08-160/HSK-A100	5056736
10	35	160	41	131	M10	Form "AD"	3.1	WSLH/10-160/HSK-A100	5056737
12	42	160	46	131	M12	Form "AD"	3.6	WSLH/12-160/HSK-A100	5056739
16	48	160	49	131	M14	Form "AD"	3.9	WSLH/16-160/HSK-A100	5056740
20	52	160	51	131	M16	Form "AD"	4.4	WSLH/20-160/HSK-A100	5056742
25	65	160	59	131	M18	Form "AD"	5.3	WSLH/25-160/HSK-A100 **	5056743

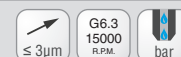

Ersatzteile und Zubehör / Spare Parts & Accessories:



- Bohrungstoleranz H4
- Kühlmittelrohr bitte separat bestellen (Siehe Seite D8)
- Im Lieferumfang enthalten: Spannschraube

- Bore tolerance H4
- Please order coolant tube separately (See page D8)
- Delivery includes: Locking screw

** 2 Spannschrauben für ID Größe = 25 / 32 / 40

** 2 locking screws for ID size = 25 / 32 / 40

Fräseraufnahmen DIN 6359 mit Kühlkanal - für Zylinderschäfte gemäß DIN 1835 B
 End mill holder to DIN 6359 with coolant channel (For cylindrical shanks according to DIN 1835 B)

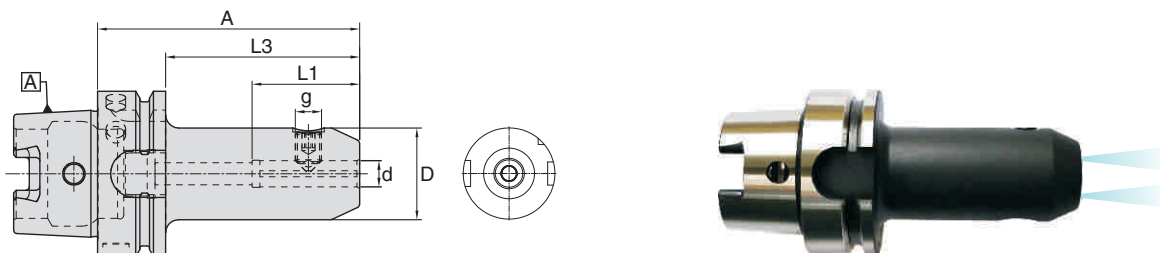

HSK-A63

d (mm)	D (mm)	A (mm)	L1 (mm)	L3 (mm)	g	Kühlmittelzufuhr Coolant supply	N/W (Kg)	Bezeichnung Designation	Ident No.
06	25	65	37	39	M6	Form "AD"	1.2	WSLH-K/06-65/HSK-A63	4601704
08	28	65	37	39	M8	Form "AD"	1.2	WSLH-K/08-65/HSK-A63	4601707
10	35	65	41	39	M10	Form "AD"	1.2	WSLH-K/10-65/HSK-A63	4601710
12	42	80	46	54	M12	Form "AD"	1.4	WSLH-K/12-80/HSK-A63	4601714
14	44	80	46	54	M12	Form "AD"	1.4	WSLH-K/14-80/HSK-A63	4601718
16	48	80	49	54	M14	Form "AD"	1.4	WSLH-K/16-80/HSK-A63	4601722
18	50	80	49	54	M14	Form "AD"	1.4	WSLH-K/18-80/HSK-A63	4601726
20	52	80	51	54	M16	Form "AD"	1.4	WSLH-K/20-80/HSK-A63	4601729
25	62.5	110	59	84	M18	Form "AD"	2.5	WSLH-K/25-110/HSK-A63 **	4601731
32	72	110	63	84	M20	Form "AD"	2.7	WSLH-K/32-110/HSK-A63 **	4601733
40	80	125	73	99	M20	Form "AD"	3.1	WSLH-K/40-125/HSK-A63 **	4601735

HSK-A100

d (mm)	D (mm)	A (mm)	L1 (mm)	L3 (mm)	g	Kühlmittelzufuhr Coolant supply	N/W (Kg)	Bezeichnung Designation	Ident No.
06	25	80	37	51	M6	Form "AD"	2.2	WSLH-K/06-80/HSK-A100	4601615
08	28	80	37	51	M8	Form "AD"	2.2	WSLH-K/08-80/HSK-A100	4601617
10	35	80	41	51	M10	Form "AD"	2.3	WSLH-K/10-80/HSK-A100	4601619
12	42	80	46	51	M12	Form "AD"	2.4	WSLH-K/12-80/HSK-A100	4601621
14	44	80	46	51	M12	Form "AD"	2.5	WSLH-K/14-80/HSK-A100	4601623
16	48	100	49	71	M14	Form "AD"	2.8	WSLH-K/16-100/HSK-A100	4601625
18	50	100	49	71	M14	Form "AD"	2.9	WSLH-K/18-100/HSK-A100	4601627
20	52	100	51	71	M16	Form "AD"	3.1	WSLH-K/20-100/HSK-A100	4601629
25	65	100	59	71	M18	Form "AD"	3.5	WSLH-K/25-100/HSK-A100 **	4601631
32	72	100	63	71	M20	Form "AD"	3.8	WSLH-K/32-100/HSK-A100 **	4601633
40	80	105	73	76	M20	Form "AD"	4.7	WSLH-K/40-105/HSK-A100 **	4601635

Ersatzteile und Zubehör / Spare Parts & Accessories:

Pg.E2

Pg.D8

- Bohrungstoleranz H4
 - Kühlmittelrohr bitte separat bestellen (Siehe Seite D8)
 - Mit 2 Kühlkanälen entlang der Aufnahmebohrung versehen
 - Im Lieferumfang enthalten: Spannschraube
- ** 2 Spannschrauben für ID Größe = 25 / 32 / 40

- Bore tolerance H4
 - Please order coolant tube separately (See page D8)
 - With two coolant channels along the side of the bore
 - Delivery includes: Locking screw
- ** 2 locking screws for ID size = 2a5 / 32 / 40

Fräseraufnahmen DIN 6359 Whistle Notch - für Zylinderschäfte gemäß DIN 1835 E
 End mill holder to DIN 6359 Whistle Notch (For cylindrical shanks according to DIN 1835 E)

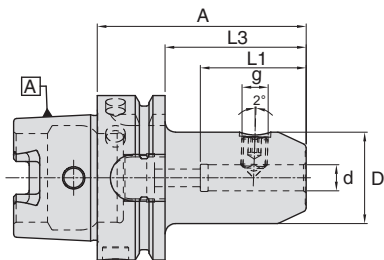

HSK-A63									
d (mm)	D (mm)	A (mm)	L1 (mm)	L3 (mm)	g	Kühlmittelzufuhr Coolant supply	N/W (Kg)	Bezeichnung Designation	Ident No.
06	25	80	37	54	M6	Form "AD"	0.9	WSLH-E/06-80/HSK-A63	4601736
08	28	80	37	54	M8	Form "AD"	1.0	WSLH-E/08-80/HSK-A63	4601737
10	35	80	41	54	M10	Form "AD"	1.1	WSLH-E/10-80/HSK-A63	4601738
12	42	90	46	64	M12	Form "AD"	1.4	WSLH-E/12-90/HSK-A63	4601739
14	44	90	46	64	M12	Form "AD"	1.4	WSLH-E/14-90/HSK-A63	4601740
16	48	100	49	74	M14	Form "AD"	1.6	WSLH-E/16-100/HSK-A63	4601741
18	50	100	49	74	M14	Form "AD"	1.7	WSLH-E/18-100/HSK-A63	4601742
20	52	100	51	74	M16	Form "AD"	1.8	WSLH-E/20-100/HSK-A63	4601743
25	62.5	110	59	84	M18	Form "AD"	2.4	WSLH-E/25-110/HSK-A63 **	4601744
32	72	110	63	84	M20	Form "AD"	2.7	WSLH-E/32-110/HSK-A63 **	4601745

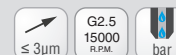

HSK-A100									
d (mm)	D (mm)	A (mm)	L1 (mm)	L3 (mm)	g	Kühlmittelzufuhr Coolant supply	N/W (Kg)	Bezeichnung Designation	Ident No.
06	25	90	37	61	M6	Form "AD"	2.3	WSLH-E/06-90/HSK-A100	4601636
08	28	90	37	61	M8	Form "AD"	2.3	WSLH-E/08-90/HSK-A100	4601637
10	35	90	41	61	M10	Form "AD"	2.5	WSLH-E/10-90/HSK-A100	4601638
12	42	100	46	71	M12	Form "AD"	2.7	WSLH-E/12-100/HSK-A100	4601639
14	44	100	46	71	M12	Form "AD"	2.7	WSLH-E/14-100/HSK-A100	4601640
16	48	100	49	71	M14	Form "AD"	2.8	WSLH-E/16-100/HSK-A100	4601641
18	50	100	49	71	M14	Form "AD"	3.0	WSLH-E/18-100/HSK-A100	4601642
20	52	110	51	81	M16	Form "AD"	3.4	WSLH-E/20-110/HSK-A100	4601643
25	65	120	59	91	M18	Form "AD"	4.0	WSLH-E/25-120/HSK-A100 **	4601644
32	72	120	63	91	M20	Form "AD"	4.4	WSLH-E/32-120/HSK-A100 **	4601645
40	80	120	73	91	M20	Form "AD"	4.7	WSLH-E/40-120/HSK-A100 **	4601646

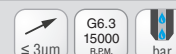

Ersatzteile und Zubehör / Spare Parts & Accessories:



- Bohrungstoleranz H4
 - Kühlmittelrohr bitte separat bestellen (Siehe Seite D8)
 - Stirnseitige Nut als Erkennungsmerkmal (im Unterschied zu Weldon)
 - Im Lieferumfang enthalten: Spannschraube und Verstellerschraube
- ** 2 Spannschrauben für ID Größe = 25 / 32 / 40

- Bore tolerance H4
 - Please order coolant tube separately (See page D8)
 - Groove on face for easy identification (to distinguish from Weldon)
 - Delivery includes : Locking screw & adjusting screw
- ** 2 locking screws for ID size = 25 / 32 / 40

Hochleistungsfräserspannfutter
Hi-Power Milling Chuck

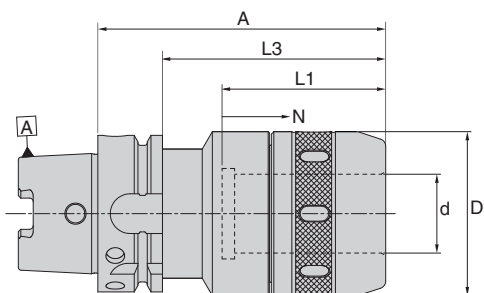

HSK-A63									
d (mm)	D (mm)	A (mm)	L1 (mm)	L3 (mm)	N	N/W (Kg)	Kühlmittelzufuhr Coolant supply	Bezeichnung Designation	Ident No.
20	52	90	60	68	15	1.6	Form "AD"	WHPMC/20-90/HSK-A63	5056123
25	58	105	70	83	15	1.9	Form "AD"	WHPMC/25-105/HSK-A63	5056125
32	66	135	75	113	15	2.8	Form "AD"	WHPMC/32-135/HSK-A63	5056126

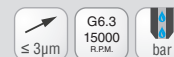

HSK-A100									
d (mm)	D (mm)	A (mm)	L1 (mm)	L3 (mm)	N	N/W (Kg)	Kühlmittelzufuhr Coolant supply	Bezeichnung Designation	Ident No.
20	52	100	60	71	15	3.0	Form "AD"	WHPMC/20-100/HSK-A100	5058646
25	58	115	70	86	15	3.5	Form "AD"	WHPMC/25-115/HSK-A100	5056129
32	66	135	75	106	15	4.2	Form "AD"	WHPMC/32-135/HSK-A100	5056132

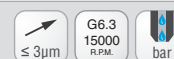

Ersatzteile und Zubehör / Spare Parts & Accessories: Pg.D10 Pg.D10 Pg.D8

- Kühlmittelrohr bitte separat bestellen (Siehe Seite D8)
- Please order coolant tube separately (See page D8)

Technische Details siehe Seite F7-F8 / Technical details refer page F7 - F8

BT MAS 403
ISO7388-2

SK DIN 69871
ISO7388-1

HSK DIN 69893

Zubehör
Accessories

Ersatzteile
Spare Parts

Technische Spezifikationen
Technical Details

Schlanke Hochleistungsfräterspannfutter
Slim Hi-Power Milling Chuck

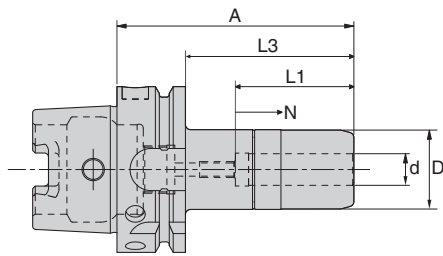

HSK-A50									
d (mm)	D (mm)	A (mm)	L1 (mm)	L3 (mm)	N	Kühlmittelzufuhr Coolant supply	N/W (Kg)	Bezeichnung Designation	Ident No.
6	25	100	36	74	8	Form "AD"	1.2	WHPMC/S06-100/HSK-A50	5105339
8	25	100	36	74	8	Form "AD"	1.2	WHPMC/S08-100/HSK-A50	5105340
10	30	100	42	74	8	Form "AD"	1.2	WHPMC/S10-100/HSK-A50	5105341

HSK-A63									
d (mm)	D (mm)	A (mm)	L1 (mm)	L3 (mm)	N	Kühlmittelzufuhr Coolant supply	N/W (Kg)	Bezeichnung Designation	Ident No.
6	25	100	36	74	8	Form "AD"	1.4	WHPMC/S06-100/HSK-A63	5105342
8	25	100	36	74	8	Form "AD"	1.4	WHPMC/S08-100/HSK-A63	5105343
10	30	100	42	74	8	Form "AD"	1.4	WHPMC/S10-100/HSK-A63	5105345
12	30	90	45	64	8	Form "AD"	1.4	WHPMC/S12-90/HSK-A63	5097495
12	30	135	45	109	8	Form "AD"	1.8	WHPMC/S12-135/HSK-A63	5097496
16	38	90	50	64	10	Form "AD"	1.5	WHPMC/S16-90/HSK-A63	5097497
16	38	135	50	109	10	Form "AD"	2.1	WHPMC/S16-135/HSK-A63	5097498
20	44	90	55	64	10	Form "AD"	1.5	WHPMC/S20-90/HSK-A63	5097499
20	44	150	55	124	10	Form "AD"	2.5	WHPMC/S20-150/HSK-A63	5097500

HSK-A100									
d (mm)	D (mm)	A (mm)	L1 (mm)	L3 (mm)	N	Kühlmittelzufuhr Coolant supply	N/W (Kg)	Bezeichnung Designation	Ident No.
12	30	100	45	71	8	Form "AD"	3.2	WHPMC/S12-100/HSK-A100	5097501
12	30	135	45	106	8	Form "AD"	3.4	WHPMC/S12-135/HSK-A100	5097503
16	38	100	50	71	10	Form "AD"	3.4	WHPMC/S16-100/HSK-A100	5097504
16	38	135	50	106	10	Form "AD"	3.8	WHPMC/S16-135/HSK-A100	5097505
20	44	100	55	71	10	Form "AD"	4.2	WHPMC/S20-100/HSK-A100	5097506
20	44	150	55	121	10	Form "AD"	4.5	WHPMC/S20-150/HSK-A100	5097507

Ersatzteile und Zubehör / Spare Parts & Accessories: Pg.D10 Pg.D8

Technische Details siehe Seite F7-F8
Refer page no.F7-F8 for more technical information

Hydrodehnspannfutter
Hydraulic Expansion Chucks

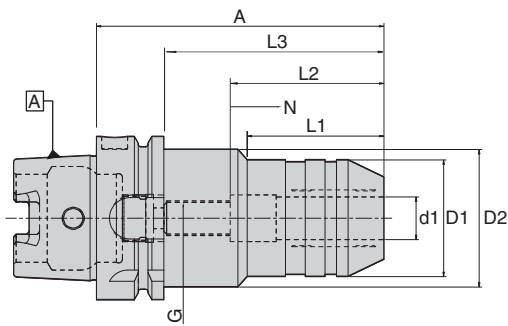

HSK-A63											
d (mm)	A (mm)	D1 (mm)	D2 (mm)	L1 (mm)	L2 (mm)	L3 (mm)	G	N	Kühlmittelzufuhr Coolant supply	Bezeichnung Designation	Ident No.
06	70	26	50	27	24	44	M5X0.8	10	Form "AD"	WHEC/06-70/HSK-A63	5056135
08	70	28	50	27	24	44	M6X1.0	10	Form "AD"	WHEC/08-70/HSK-A63	5056136
10	80	30	50	32	35	54	M8X1.0	10	Form "AD"	WHEC/10-80/HSK-A63	5056137
12	85	32	50	37	40	59	M10X1.0	10	Form "AD"	WHEC/12-85/HSK-A63	5056138
14	85	34	50	37	40	59	M10X1.0	10	Form "AD"	WHEC/14-85/HSK-A63	5056139
16	90	38	50	42	46	64	M12X1.0	10	Form "AD"	WHEC/16-90/HSK-A63	5056140
18	90	40	50	42	46	64	M12X1.0	10	Form "AD"	WHEC/18-90/HSK-A63	5056141
20	90	42	50	42	48	64	M16X1.0	10	Form "AD"	WHEC/20-90/HSK-A63	5056143
25	120	57	63	48	59	94	M16X1.0	10	Form "AD"	WHEC/25-120/HSK-A63	5056146
32	125	64	75	55	63	99	M16X1.0	10	Form "AD"	WHEC/32-125/HSK-A63	5056147

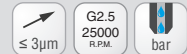

HSK-A100											
d (mm)	D1 (mm)	D2 (mm)	A (mm)	L1 (mm)	L2 (mm)	L3 (mm)	G	N	Kühlmittelzufuhr Coolant supply	Bezeichnung Designation	Ident No.
06	26	50	75	27	24	46	M5X0.8	10	Form "AD"	WHEC/06-75/HSK-A100	5056148
08	28	50	75	27	24	46	M6X1.0	10	Form "AD"	WHEC/08-75/HSK-A100	5056149
10	30	50	90	32	35	61	M8X1.0	10	Form "AD"	WHEC/10-90/HSK-A100	5056153
12	32	50	95	37	40	66	M10X1.0	10	Form "AD"	WHEC/12-95/HSK-A100	5056154
14	34	50	95	37	40	66	M10X1.0	10	Form "AD"	WHEC/14-95/HSK-A100	5056155
16	38	50	100	42	46	71	M12X1.0	10	Form "AD"	WHEC/16-100/HSK-A100	5056156
18	40	50	100	42	46	71	M12X1.0	10	Form "AD"	WHEC/18-100/HSK-A100	5056157
20	42	50	105	42	48	76	M16X1.0	10	Form "AD"	WHEC/20-105/HSK-A100	5056158
25	57	63	110	48	59	81	M16X1.0	10	Form "AD"	WHEC/25-110/HSK-A100	5056159
32	64	75	110	55	63	81	M16X1.0	10	Form "AD"	WHEC/32-110/HSK-A100	5056160

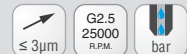

Ersatzteile und Zubehör / Spare Parts & Accessories:



• Kühlmittelrohr bitte separat bestellen (Siehe Seite D8)

• Please order coolant tube separately (See page D8)

BT MAS 403
ISO7388-2

SK DIN 69871
ISO7388-1

HSK DIN 69893

Zubehör
Accessories

Ersatzteile
Spare Parts

Technische Spezifikationen
Technical Details

NC Bohrfutter
NC Drill Chucks

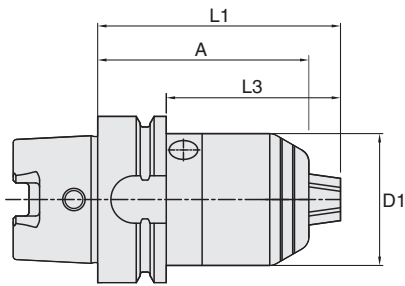

HSK-A63									
D (mm)	A (mm)	L (mm)	L3 (mm)	Bereich Range	Kühlmittelzufuhr Coolant supply	N/W (Kg)	Bezeichnung Designation	Ident No.	
50	98	110	84	1-16	Form "AD"	1.56	WNDC/1-16-98/HSK-A63	5056229	

HSK-A100									
D (mm)	A (mm)	L (mm)	L3 (mm)	Bereich Range	Kühlmittelzufuhr Coolant supply	N/W (Kg)	Bezeichnung Designation	Ident No.	
50	104	116	87	1-16	Form "AD"	2.91	WNDC/1-16-104/HSK-A100	5056231	

- | | |
|---|--|
| <ul style="list-style-type: none"> • kompakte Bauweise • hohe Rundlaufgenauigkeit • sichere Spannung durch selbsthemmendes Getriebe • für Rechts - und Linkslauf geeignet | <ul style="list-style-type: none"> • compact design • high run-out accuracy • secure clamping due to self-locking gear • suitable for clockwise and counter-clockwise operations |
|---|--|

Zwischenhülsen für Morse-Kegel mit Anzugsgewinde DIN 6364 / 228A
 Adaptor sleeves for Morse taper with thread DIN 6364 / 228A

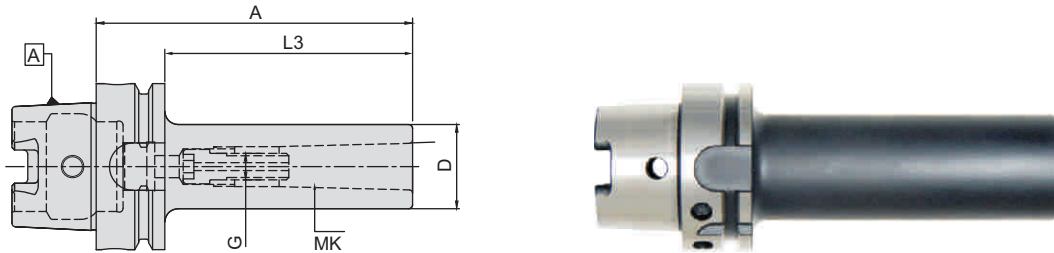

HSK-A63									
MK	D (mm)	L3 (mm)	G	Kühlmittelzufuhr Coolant supply	N/W (Kg)	Bezeichnung Designation	Ident No.		
1	25	100	M6	-	1.5	WMTB/MT1-100/HSK-A63	4601750		
2	32	120	M10	-	2.0	WMTB/MT2-120/HSK-A63	4601751		
3	40	140	M12	-	2.2	WMTB/MT3-140/HSK-A63	4601752		
4	48	160	M16	-	2.5	WMTB/MT4-160/HSK-A63	4601753		

HSK-A100									
MK	D (mm)	A (mm)	L3 (mm)	G	Kühlmittelzufuhr Coolant supply	N/W (Kg)	Bezeichnung Designation	Ident No.	
1	25	110	81	M6	-	2.4	WMTB/MT1-110/HSK-A100	4601652	
2	32	120	91	M10	-	2.4	WMTB/MT2-120/HSK-A100	4601653	
3	40	150	121	M12	-	3.0	WMTB/MT3-150/HSK-A100	4601654	
4	48	170	141	M16	-	3.4	WMTB/MT4-170/HSK-A100	4601655	
5	63	200	171	M20	-	4.5	WMTB/MT5-200/HSK-A100	4601656	

Ersatzteile und Zubehör / Spare Parts & Accessories: Pg.E5 Pg.E5 Pg.D8

- Im Lieferumfang enthalten: eingebaute Innensechskantschraube
- Kühlmittelrohr bitte separat bestellen (Siehe Seite D8)
- Delivery includes : built-in draw screw
- Please order coolant tube separately (see page D8)

BT MAS 403
ISO7388-2

SK DIN 69871
ISO7388-1

HSK DIN 69893



Zubehör
Accessories

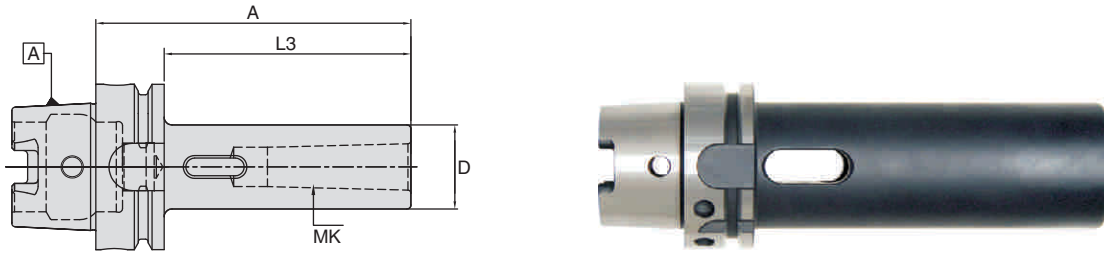

Ersatzteile
Spare Parts

Technische Spezifikationen
Technical Details

Zwischenhülsen für Morse-Kegel mit Austreibblappen DIN 6383
 Adaptor sleeves for Morse taper with tang to DIN 6383



HSK-A63							 
MK	D (mm)	A (mm)	L3 (mm)	Kühlmittelezufuhr Coolant supply	N/W (Kg)	Bezeichnung Designation	Ident No.
1	25	100	74	-	1.5	WMTA/MT1-100/HSK-A63	4601746
2	32	120	94	-	2.0	WMTA/MT2-120/HSK-A63	4601747
3	40	140	114	-	2.2	WMTA/MT3-140/HSK-A63	4601748
4	48	160	134	-	2.5	WMTA/MT4-160/HSK-A63	4601749

HSK-A100							 
MK	D (mm)	A (mm)	L3 (mm)	Kühlmittelezufuhr Coolant supply	N/W (Kg)	Bezeichnung Designation	Ident No.
1	25	110	81	-	3.4	WMTA/MT1-110/HSK-A100	4601647
2	32	120	91	-	3.8	WMTA/MT2-120/HSK-A100	4601648
3	40	150	121	-	4.0	WMTA/MT3-150/HSK-A100	4601649
4	48	170	141	-	4.6	WMTA/MT4-170/HSK-A100	4601650
5	63	200	171	-	5.2	WMTA/MT5-200/HSK-A100	4601651

• Kühlmittelrohr bitte separat bestellen (Siehe Seite D8) • Please order coolant tube separately (See page D8)

Aufnahmen für Einschraubfräser
Chucks for threaded milling heads

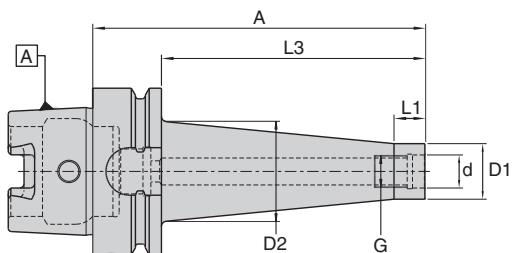

HSK-A63									
G	d (mm)	D1 (mm)	D2 (mm)	A (mm)	L1 (mm)	L3 (mm)	Kühlmittelzufuhr Coolant supply	Bezeichnung Designation	Ident No.
M8	8.5	13.8	15	51	12	25	Form "AD"	WTA/M8-51/HSK-A63	5055783
M8	8.5	13.8	23	76	12	50	Form "AD"	WTA/M8-76/HSK-A63	5055784
M8	8.5	13.8	25	101	12	75	Form "AD"	WTA/M8-101/HSK-A63	5055785
M10	10.5	18.0	23	51	12	25	Form "AD"	WTA/M10-51/HSK-A63	5055786
M10	10.5	18.0	25	76	12	50	Form "AD"	WTA/M10-76/HSK-A63	5055787
M10	10.5	18.0	35	126	12	100	Form "AD"	WTA/M10-126/HSK-A63	5055788
M10	10.5	18.0	45	176	12	150	Form "AD"	WTA/M10-176/HSK-A63	5055789
M12	12.5	21.0	24	51	12	25	Form "AD"	WTA/M12-51/HSK-A63	5055790
M12	12.5	21.0	30	76	12	50	Form "AD"	WTA/M12-76/HSK-A63	5055791
M12	12.5	21.0	38	126	12	100	Form "AD"	WTA/M12-126/HSK-A63	5055792
M12	12.5	21.0	45	176	12	150	Form "AD"	WTA/M12-176/HSK-A63	5055793
M16	17.0	29.0	29	51	12	25	Form "AD"	WTA/M16-51/HSK-A63	5055794
M16	17.0	29.0	34	76	12	50	Form "AD"	WTA/M16-76/HSK-A63	5055795
M16	17.0	29.0	40	126	12	100	Form "AD"	WTA/M16-126/HSK-A63	5055796
M16	17.0	29.0	48	176	12	150	Form "AD"	WTA/M16-176/HSK-A63	5055797

HSK-A100									
G	d (mm)	D1 (mm)	D2 (mm)	A (mm)	L1 (mm)	L3 (mm)	Kühlmittelzufuhr Coolant supply	Bezeichnung Designation	Ident No.
M10	10.5	18.0	25	79	12	50	Form "AD"	WTA/M10-79/HSK-A100	5055798
M10	10.5	18.0	35	129	12	100	Form "AD"	WTA/M10-129/HSK-A100	5055799
M10	10.5	18.0	45	179	12	150	Form "AD"	WTA/M10-179/HSK-A100	5055800
M12	12.5	21.0	30	79	12	50	Form "AD"	WTA/M12-79/HSK-A100	5055801
M12	12.5	21.0	38	129	12	100	Form "AD"	WTA/M12-129/HSK-A100	5055802
M12	12.5	21.0	45	179	12	150	Form "AD"	WTA/M12-179/HSK-A100	5055803
M16	17.0	29.0	34	79	12	50	Form "AD"	WTA/M16-79/HSK-A100	5055804
M16	17.0	29.0	40	129	12	100	Form "AD"	WTA/M16-129/HSK-A100	5055805
M16	17.0	29.0	48	179	12	150	Form "AD"	WTA/M16-179/HSK-A100	5055806

Ersatzteile und Zubehör / Spare Parts & Accessories: Pg.D8

- Kühlmittelrohr bitte separat bestellen (Siehe Seite D8)
- Siehe Seite D12 für Einschraubfräser Verlängerung & Reduzierung
- Please order coolant tube separately (See page D8)
- Refer page D12 for Threaded Arbor extensions & reductions.

BT MAS 403
ISO7388-2

SK DIN 69871
ISO7388-1

HSK DIN 69893

Zubehör
Accessories

Ersatzteile
Spare Parts

Technische Spezifikationen
Technical Details

Aufsteckfräserdorne DIN 6358 mit Längs- und Quernut (Kombi)
Shell mill holder with DIN 6358 (Combi)

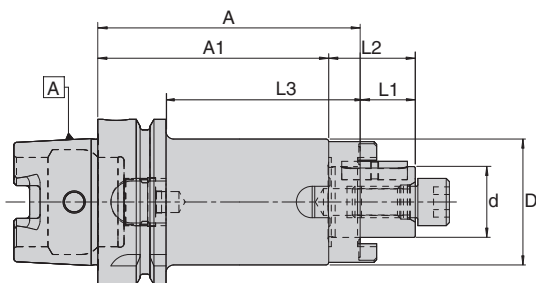

HSK-A63										
d (mm)	D (mm)	A (mm)	A1 (mm)	L1 (mm)	L2 (mm)	L3 (mm)	Kühlmittelezufuhr Coolant supply	N/W (kg)	Bezeichnung Designation	Ident No.
16	32	60	50	27	17	34	-	1.0	WFSH/16-60/HSK-A63	4601754
22	40	60	48	31	19	34	-	1.0	WFSH/22-60/HSK-A63	4601756
27	48	60	48	33	21	34	-	1.2	WFSH/27-60/HSK-A63	4601758
32	53	60	46	38	24	34	-	1.4	WFSH/32-60/HSK-A63	4601760
40	70	70	56	41	27	44	-	1.8	WFSH/40-70/HSK-A63 *	4601762
16	32	100	90	27	17	74	-	1.4	WFSH/16-100/HSK-A63	4601755
22	40	100	88	31	19	74	-	1.5	WFSH/22-100/HSK-A63	4601757
27	48	100	88	33	21	74	-	1.8	WFSH/27-100/HSK-A63	4601759
32	58	100	86	38	24	74	-	2.5	WFSH/32-100/HSK-A63	4601761
40	70	100	86	41	27	74	-	2.8	WFSH/40-100/HSK-A63 *	5055763



HSK-A63										
d (mm)	D (mm)	A (mm)	A1 (mm)	L1 (mm)	L2 (mm)	L3 (mm)	Kühlmittelezufuhr Coolant supply	N/W (kg)	Bezeichnung Designation	Ident No.
16	32	160	150	27	17	134	-	2.5	WFSH/16-160/HSK-A63	5055764
22	40	160	148	31	19	134	-	2.6	WFSH/22-160/HSK-A63	5055765
27	48	160	148	33	21	134	-	2.8	WFSH/27-160/HSK-A63	5055766
32	58	160	146	38	24	134	-	3.3	WFSH/32-160/HSK-A63	5055767
40	70	160	146	41	27	134	-	3.5	WFSH/40-160/HSK-A63 *	5055772



HSK-A100										
d (mm)	D (mm)	A (mm)	A1 (mm)	L1 (mm)	L2 (mm)	L3 (mm)	Kühlmittelezufuhr Coolant supply	N/W (kg)	Bezeichnung Designation	Ident No.
16	32	60	50	27	17	31	-	2.4	WFSH/16-60/HSK-A100	5055773
22	40	60	48	31	19	31	-	2.6	WFSH/22-60/HSK-A100	4601658
27	48	60	48	33	21	31	-	2.8	WFSH/27-60/HSK-A100	4601659
32	58	60	46	38	24	31	-	3.0	WFSH/32-60/HSK-A100	4601660
40	70	70	56	41	27	41	-	3.4	WFSH/40-70/HSK-A100 *	4601661



Ersatzteile und Zubehör / Spare Parts & Accessories: Pg.E3 Pg.E4 Pg.E3 Pg.D8 Pg.D8

- Im Lieferumfang enthalten: Passfeder, Mitnehmerring, Fräseranzugsschraube und Spannschrauben (DIN 912)
- Spannschrauben (DIN 6367) bitte separat bestellen (Siehe Seite E3)
- * Im Lieferumfang enthalten: Spannschrauben (DIN 912 & DIN 6367)
- Kühlmittelrohr bitte separat bestellen (Siehe Seite D8)

- Delivery includes : Parallel key, drive ring, clamping screw and locking screw (DIN 912)
- Please order locking screw (DIN 6367) separately (refer page E3)
- * Delivery includes : Locking screw (both DIN 912 & DIN 6367)
- Please order coolant tube separately (See page D8)

Aufnahmedorn mit Innenzentrierung DIN 6357 und vergrößertem Bunddurchmesser
Shell mill holder DIN 6357 for cutters with drive key

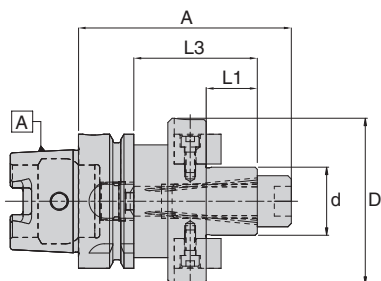

HSK-A50								
d (mm)	D (mm)	A (mm)	L1 (mm)	L3 (mm)	Kühlmittelezufuhr Coolant supply	N/W (kg)	Bezeichnung Designation	Ident No.
16	38	50	17	24	Form "AD"	0.8	WSMH/16-50/HSK-A50	5103448
22	48	60	19	34	Form "AD"	1.0	WSMH/22-60/HSK-A50	5103450
27	58	60	21	34	Form "AD"	1.1	WSMH/27-60/HSK-A50	5103452
32	78	60	24	34	Form "AD"	1.4	WSMH/32-60/HSK-A50	5103454
16	38	100	17	74	Form "AD"	1.2	WSMH/16-100/HSK-A50	5103457
22	48	100	19	74	Form "AD"	1.6	WSMH/22-100/HSK-A50	5103459
27	58	100	21	74	Form "AD"	1.9	WSMH/27-100/HSK-A50	5103461
32	78	100	24	74	Form "AD"	2.7	WSMH/32-100/HSK-A50	5103462

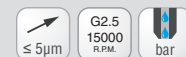

HSK-A63								
d (mm)	D (mm)	A (mm)	L1 (mm)	L3 (mm)	Kühlmittelezufuhr Coolant supply	N/W (kg)	Bezeichnung Designation	Ident No.
16	38	50	17	24	Form "AD"	1.1	WSMH/16-50/HSK-A63	4601763
22	48	50	19	24	Form "AD"	1.1	WSMH/22-50/HSK-A63	4601765
27	58	60	21	34	Form "AD"	1.3	WSMH/27-60/HSK-A63	4601767
32	78	60	24	34	Form "AD"	1.4	WSMH/32-60/HSK-A63	4601769
40	88	60	27	34	Form "AD"	1.9	WSMH/40-60/HSK-A63+*	4601771
16	38	100	17	74	Form "AD"	1.4	WSMH/16-100/HSK-A63	4601764
22	48	100	19	74	Form "AD"	1.8	WSMH/22-100/HSK-A63	4601766
27	58	100	21	74	Form "AD"	2.0	WSMH/27-100/HSK-A63	4601768
32	78	100	24	74	Form "AD"	2.6	WSMH/32-100/HSK-A63	4601770
40	88	100	27	74	Form "AD"	3.1	WSMH/40-100/HSK-A63+*	4601772

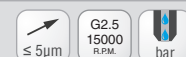

HSK-A100								
d (mm)	D (mm)	A (mm)	L1 (mm)	L3 (mm)	Kühlmittelezufuhr Coolant supply	N/W (kg)	Bezeichnung Designation	Ident No.
16	38	50	17	21	Form "AD"	2.3	WSMH/16-50/HSK-A100	5056120
22	48	50	19	21	Form "AD"	2.5	WSMH/22-50/HSK-A100	4601663
27	58	50	21	21	Form "AD"	2.7	WSMH/27-50/HSK-A100	4601664
32	78	50	24	21	Form "AD"	2.8	WSMH/32-50/HSK-A100	4601665
40	88	60	27	31	Form "AD"	3.8	WSMH/40-60/HSK-A100+*	4601666
60	129	70	40	41	Form "AD"	6.0	WSMH/60-70/HSK-A100+	5056122

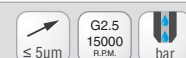

Ersatzteile und Zubehör / Spare Parts & Accessories: Pg.D8 Pg.E3 Pg.E4 Pg.E4 Pg.D8

- Kühlbohrung an der Stirnseite Standard bei allen Grundhaltern
+ ID = Ø 40, D = Ø 60 Mit 4 zusätzlichen Gewindebohrungen nach DIN 2079
- Kühlmittelrohr bitte separat bestellen (Siehe Seite D8)
- Im Lieferumfang enthalten: Mitnehmersteine, Fräseranzugsschraube und Spannschrauben (DIN 912)
- * Im Lieferumfang enthalten: Spannschrauben (DIN 912 & DIN 6367)
- Spannschrauben (DIN6367) bitte separat bestellen (Siehe Seite E3)

- Coolant bore on the pilot face (holder with Form "AD") as standard for all holders
+ ID = Ø 40, D = Ø 60 With additional 4 screw holes to DIN 2079
- Please order coolant tube separately (See page D8)
- Delivery includes : Drive keys, clamping screw and locking screw (DIN 912)
- * Delivery includes : Locking screw (both DIN 912 & DIN 6367)
- Please order locking screw (DIN6367) separately (refer page E3)

Bohrstangenrohlinge
Boring bar blanks

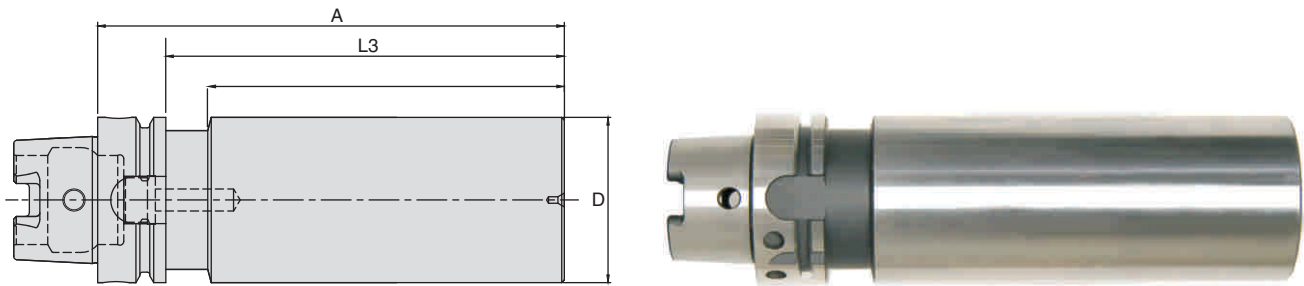

HSK-A32							35 ± 5 HRC
D (mm)	A (mm)	L3 (mm)	Kühlmittelezufuhr Coolant supply	N/W (kg)	Bezeichnung Designation	Ident No.	
35	150	130	-	1.1	WBBB/35-150/HSK-A32	9202418	

HSK-A40							35 ± 5 HRC
D (mm)	A (mm)	L3 (mm)	Kühlmittelezufuhr Coolant supply	N/W (kg)	Bezeichnung Designation	Ident No.	
40	150	130	-	1.4	WBBB/40-150/HSK-A40	9202419	
52	200	180	-	2.1	WBBB/52-200/HSK-A40	9202420	

HSK-A50							35 ± 5 HRC
D (mm)	A (mm)	L3 (mm)	Kühlmittelezufuhr Coolant supply	N/W (kg)	Bezeichnung Designation	Ident No.	
52	200	174	-	2.8	WBBB/52-200/HSK-A50	9202421	
63	200	174	-	3.2	WBBB/63-200/HSK-A50	9202422	

HSK-A63							35 ± 5 HRC
D (mm)	A (mm)	L3 (mm)	Kühlmittelezufuhr Coolant supply	N/W (kg)	Bezeichnung Designation	Ident No.	
63	200	174	-	4.8	WBBB/63-200/HSK-A63	5056270	
80	250	224	-	9.0	WBBB/80-250/HSK-A63	5056271	

HSK-A100							35 ± 5 HRC
D (mm)	A (mm)	L3 (mm)	Kühlmittelezufuhr Coolant supply	N/W (kg)	Bezeichnung Designation	Ident No.	
63.0	200	171	-	6.2	WBBB/63-200/HSK-A100	5056272	
80.0	250	221	-	9.1	WBBB/80-250/HSK-A100	5056273	
97.5	250	221	-	15.0	WBBB/97.5-250/HSK-A100	5056274	

Ersatzteile und Zubehör / Spare Parts & Accessories:  Pg.D8

- Im Lieferumfang enthalten: Bund gehärtet und geschliffen, Schaft weich
- Kühlmittelrohr bitte separat bestellen (Siehe Seite D8)
- Delivery includes : Shank and flange hardened, body left soft
- Please order coolant tube separately (see page D8)

Pendelhalter (PN / HSK) Kegel - Hohlchaft DIN 69893A mit Kühlmitteldurchführung
 Floating chucks (PN / HSK) - Hollow taper shank DIN 69893A with internal coolant feed

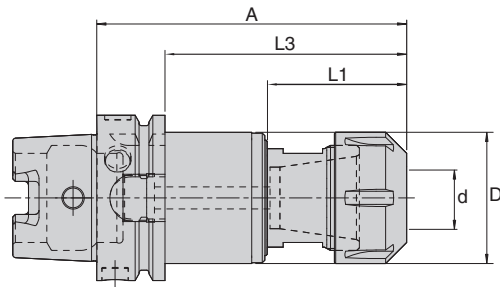

HSK-A63									
Pendelweg Floating Range	d (mm)	D (mm)	A (mm)	L1 (mm)	L3 (mm)	Kühlmittelzufuhr Coolant supply	N/W (kg)	Bezeichnung Designation	Ident No.
+/-0,25	6-16	50	112	47	86	Form "AD"	1,4	PN50-IK/HSK-A63-ESX25	6774212
+/-0,25	8-20	50	118	53	92	Form "AD"	1,5	PN50-IK/HSK-A63-ESX32	6730237

• Lieferung ohne Spannzange und Dichtscheibe • Delivery excludes collet and sealing disc

Mit Bilz-Modular-Schaft MS ähnlich DIN 1835 zum Kombinieren mit Werkzeugaufnahmen
 Bilz-WA mit Kühlmitteldurchführung
 PN/MS: BILZ modular shank MS similar to DIN 1835
 For combination with BILZ WA tool holders (with internal coolant)

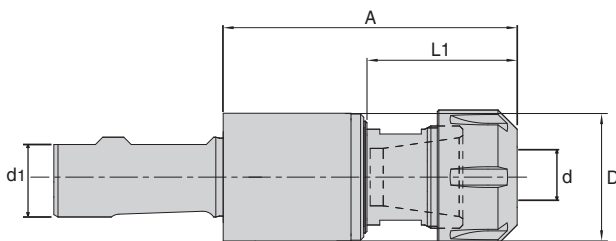

20 bar									
Pendelweg Floating Range	d (mm)	D (mm)	d1 (mm)	A (mm)	L1 (mm)	Bezeichnung Designation	Ident No.		
+/-0,25	5-13	40	20	80	45	PN40-IK/MS20-ESX20	6730247		
+/-0,25	6-16	50	25	88	47	PN50-IK/MS25-ESX25	9168161		
+/-0,25	8-20	50	32	94	53	PN50-IK/MS25-ESX32	6730239		

• Lieferung ohne Spannzange und Dichtscheibe • Delivery excludes collet and sealing disc

BT MAS 403
ISO7388-2

SK DIN 69871
ISO7388-1

HSK DIN 69893

Zubehör
Accessories

Ersatzteile
Spare Parts

Technische Spezifikationen
Technical Details

Kontrolldorn
Test Arbor

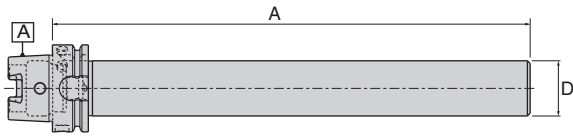

HSK-A63						↗ ≤ 2µm
D (mm)	A (mm)	Kühlmittelezufuhr Coolant supply	N/W (kg)	Bezeichnung Designation	Ident No.	
40	346	-	4.5	WTMM/40-346/HSK-A63	5056275	

HSK-A100						↗ ≤ 2µm
D (mm)	A (mm)	Kühlmittelezufuhr Coolant supply	N/W (kg)	Bezeichnung Designation	Ident No.	
50	349	-	8.5	WTMM/50-349/HSK-A100	5056276	

- Kontrolldorne im Holzkasten geliefert
- Delivered in wooden box

DIN 69893 (HSK-E) Werkzeugaufnahmen
DIN 69893 (HSK-E) Tool Holders

Spannzangenfutter ER *
Collet chuck ER * C23

Fräseraufnahmen (Weldon) *
End mill holder (Weldon) * C24

* Die oben genannten Produkte sind nicht lagerhaltig und können auf Anfrage angeboten werden
* The above mentioned products are not stock articles and can be offered upon request

DIN 69893 (HSK-F-63) Werkzeugaufnahmen
DIN 69893 (HSK-F-63) Tool Holders

Spannzangenfutter ER *
Collet chuck ER * C25

* Die oben genannten Produkte sind nicht lagerhaltig und können auf Anfrage angeboten werden
* The above mentioned products are not stock articles and can be offered upon request

Spannzangenfutter Typ ER für Spannzangen ISO 15488 (DIN 6499) (HSK-E)

Collet chuck type ER for collets to ISO 15488 (DIN 6499) (HSK-E)

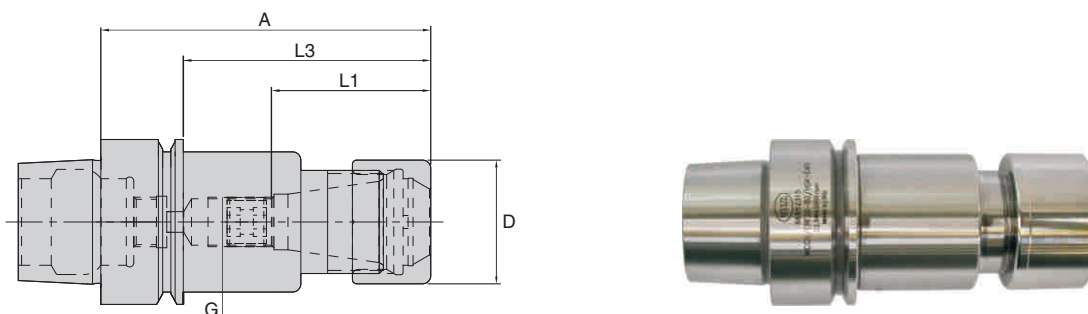

HSK-E32											
 											
Spannzange Collet Type	Bereich Range	D (mm)	A (mm)	L1 (mm)	L3 (mm)	N	G	Kühlmittelzufuhr Coolant supply	N/W (Kg)	Bezeichnung Designation	Ident No.
ER16	1-10	27.1	65	65	65	65	M10	Form "AD"	0.3	WCCH/ERF16-65/HSK-E32	5100028
ER20	1-13	33	70	70	70	70	M12	Form "AD"	0.4	WCCH/ERF20-70/HSK-E32	5100030
ER25	2-16	40	70	70	70	70	M16	Form "AD"	0.4	WCCH/ERF25-70/HSK-E32	5100031

HSK-E40											
 											
Spannzange Collet Type	Bereich Range	D (mm)	A (mm)	L1 (mm)	L3 (mm)	N	G	Kühlmittelzufuhr Coolant supply	N/W (Kg)	Bezeichnung Designation	Ident No.
ER16	1-10	27.1	70	70	70	70	M10	Form "AD"	0.4	WCCH/ERF16-70/HSK-E40	5100032
ER20	1-13	33	80	80	80	80	M12	Form "AD"	0.5	WCCH/ERF20-80/HSK-E40	5100033
ER25	2-16	40	80	80	80	80	M16	Form "AD"	0.5	WCCH/ERF25-80/HSK-E40	5100034
ER16	1-10	27.1	120	120	120	120	M10	Form "AD"	0.6	WCCH/ERF16-120/HSK-E40	5100035
ER20	1-13	33	120	120	120	120	M12	Form "AD"	0.5	WCCH/ERF20-120/HSK-E40	5100036
ER25	2-16	40	120	120	120	120	M16	Form "AD"	0.75	WCCH/ERF25-120/HSK-E40	5100037

HSK-E50											
 											
Spannzange Collet Type	Bereich Range	D (mm)	A (mm)	L1 (mm)	L3 (mm)	N	G	Kühlmittelzufuhr Coolant supply	N/W (Kg)	Bezeichnung Designation	Ident No.
ER16	1-10	27.1	80	80	80	80	M10	Form "AD"	0.9	WCCH/ERF16-80/HSK-E50	5100039
ER20	1-13	33	95	95	95	95	M12	Form "AD"	1.00	WCCH/ERF20-95/HSK-E50	5100040
ER25	2-16	40	95	95	95	95	M16	Form "AD"	1.05	WCCH/ERF25-95/HSK-E50	5100041
ER32	2-20	48	100	100	100	100	M22X1.5	Form "AD"	0.85	WCCH/ERF32-100/HSK-E50	5100042

Ersatzteile und Zubehör / Spare Parts & Accessories:



Pg.D2



Pg.D15



Pg.D14

- Kühlmittelrohr bitte separat bestellen (Siehe Seite D8)
- Im Lieferumfang enthalten: Spannmutter (gewuchtet) und Einstellschraube

- Please order coolant tube separately (See page D8)
- Delivery includes : Friction nut (balanced)

Fräseraufnahmen (Weldon) - für Zylinderschäfte gemäß DIN 1835B (HSK-E)
 End mill holder (Weldon) - For cylindrical shanks according to DIN 1835B (HSK-E)

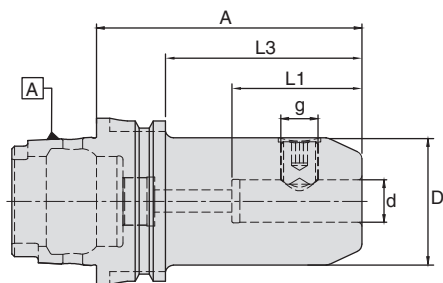

HSK-E32									
d (mm)	D (mm)	A (mm)	L1 (mm)	L3 (mm)	g	Kühlmittelzufuhr Coolant supply	N/W (Kg)	Bezeichnung Designation	Ident No.
06	25	60	37	40	M6	Form "AD"	0.3	WSLH/06-60/HSK-E32	5100228
08	28	60	37	40	M8	Form "AD"	0.3	WSLH/08-60/HSK-E32	5100229
10	35	65	41	45	M10	Form "AD"	0.4	WSLH/10-65/HSK-E32	5100230
12	42	75	46	55	M12	Form "AD"	0.6	WSLH/12-75/HSK-E32	5100231
16	48	75	49	55	M14	Form "AD"	0.7	WSLH/16-75/HSK-E32	5100232

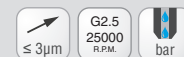

HSK-E40									
d (mm)	D (mm)	A (mm)	L1 (mm)	L3 (mm)	g	Kühlmittelzufuhr Coolant supply	N/W (Kg)	Bezeichnung Designation	Ident No.
06	25	60	37	40	M6	Form "AD"	0.4	WSLH/06-60/HSK-E40	5100233
08	28	60	37	40	M8	Form "AD"	0.4	WSLH/08-60/HSK-E40	5100234
10	34	65	41	45	M10	Form "AD"	0.5	WSLH/10-65/HSK-E40	5100235
12	42	70	46	50	M12	Form "AD"	0.6	WSLH/12-70/HSK-E40	5100237
16	48	80	49	60	M14	Form "AD"	0.8	WSLH/16-80/HSK-E40	5100238
20	52	80	52	60	M16	Form "AD"	0.8	WSLH/20-80/HSK-E40	5100239

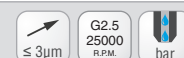

HSK-E50									
d (mm)	D (mm)	A (mm)	L1 (mm)	L3 (mm)	g	Kühlmittelzufuhr Coolant supply	N/W (Kg)	Bezeichnung Designation	Ident No.
06	25	65	37	39	M6	Form "AD"	0.6	WSLH/06-65/HSK-E50	5100240
08	28	65	37	39	M8	Form "AD"	0.6	WSLH/08-65/HSK-E50	5100241
10	35	65	41	39	M10	Form "AD"	0.7	WSLH/10-65/HSK-E50	5100242
12	42	80	46	54	M12	Form "AD"	0.7	WSLH/12-80/HSK-E50	5100243
16	48	80	49	54	M14	Form "AD"	0.7	WSLH/16-80/HSK-E50	5100244
20	52	80	52	54	M16	Form "AD"	0.1	WSLH/20-80/HSK-E50	5100245

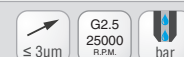

Ersatzteile und Zubehör / Spare Parts & Accessories: Pg.E2

- Bohrungstoleranz H4
- Kühlmittelrohr bitte separat bestellen (Siehe Seite D8)
- Im Lieferumfang enthalten: Spannschraube

- Bore tolerance H4
- Please order coolant tube separately (See page D8)
- Delivery includes : Locking screw

BT MAS 403
ISO7388-2

SK DIN 69871
ISO7388-1

HSK DIN 69893

Zubehör
Accessories

Ersatzteile
Spare Parts

Technische Spezifikationen
Technical Details

Spannzangenfutter mit Hohlenschaftkegel HSK-F63
 Collet chuck with hollow taper shank HSK-F63

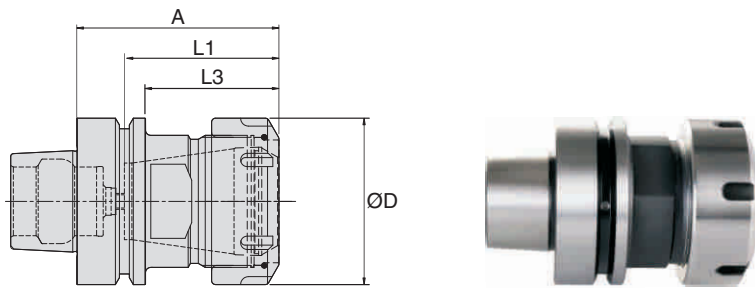

HSK-F63										
Spannzange Collet Type	Bereich Range	D (mm)	A (mm)	L1 (mm)	L3 (mm)	N/W (Kg)	Bezeichnung Designation	Ident No.		
ER25	2-16	42	70.0	47.0	47.0	1.0	WCCH/ERB25-70/HSK-F63-DX	5100248		
ER32	2-20	50	73.0	47.0	47.0	1.0	WCCH/ERB32-73/HSK-F63-DX	5100249		
ER32	2-20	50	73.0	47.0	47.0	1.0	WCCH/ERB32-73/HSK-F63-SX	5100250		
ER40	3-26	63	76.5	58.5	50.5	1.2	WCCH/ERB40-76.5/HSK-F63-DX	5100251		
ER40	3-26	63	76.5	58.5	50.5	1.2	WCCH/ERB40-76.5/HSK-F63-SX	5100252		

Ersatzteile und Zubehör / Spare Parts & Accessories: Pg.D2 Pg.C22 Pg.D3

Spannmutter ERB DIN 6499
 Clamping nut ERB to DIN 6499-balanced

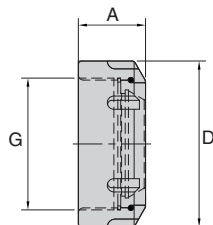

Bezeichnung Designation	Abmessung Size	D (mm)	L (mm)	G	Ident. No.
ERB25-HP	2-16	42	20.0	M32X1.5	5104121
ERB32-HP	2-20	50	22.5	M40X1.5	5104122
ERB40-HP	3-26	63	25.5	M50X1.5	5104123

Spannzangen
Collets D2

Spannschlüssel
Wrench D3

Spannmuttern
Clamping nuts D4

Dichtscheiben
Sealing discs D5

Anzugsbolzen
Pull studs D6 - D7

Zylinderschaft
Cylinder Shank D8

Spannschlüssel DIN 6368
Spanner to DIN 6368 D8

Kühlmittelrohr
Coolant tube D8

Montageschlüssel für Kühlmittelrohr
Installation wrench for coolant pipe D9

Zylindrische Spannzange mit Längennachstellung
Adjustable straight collet D10

WHC - Reduzierbuchsen
WHC - Reduction sleeves D11

WTA - Verlängerung & Reduzierung
WTA - Extensions & Reductions D12

Super collet Spannzangen
Super Collet D13 - D15

Montagevorrichtung
Assembly device D16 - D17

Micro Spannfutter Verlängerungen MCE
Micro chuck extensions MCE D18

Spannzangen DIN 6499 System ER
Collets DIN 6499 ER-System

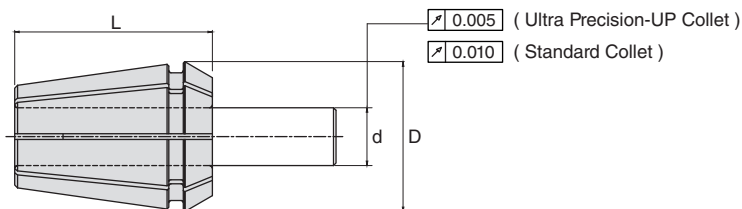

Spannbereich Clamping Ranged (mm)	424E ER 11-... D=11.5, L=18mm (1.0-7.0) Ident No.	426E ER 16-... D=17, L=27mm (1.0-10.0) Ident No.	428E ER 20-... D=21, L=31mm (1.0-13.0) Ident No.	430E ER 25-... D=26, L=35mm (2.0-16.0) Ident No.	470E ER 32-... D=33, L=40mm (2.0-20.0) Ident No.	472E ER 40-... D=41, L=46mm (3.0-26.0) Ident No.
1.0-0.5(1/32")	5056179	5057132				
..UP		6956076				
2.0-1.0(1/16")	5056181	5057134	5057149	5056198	5056200	
..UP		6951390	6950718	6956077	6954804	
3.0-2.0	5056182	5057135	5057151	5057171	5057226	5056211
..UP		6950577	6954121	6950639	6954216	
4.0-3.0(5/32")	5056184	5057136	5057152	5057172	5057228	5057255
..UP		6951316	6954011	6951451	6954116	
5.0-4.0(3/16")	5056187	5057137	5057159	5057173	5057229	5057257
..UP		6944020	6953669	6951452	6954117	
6.0-5.0(7/32")	5056189	5057138	5057160	5057174	5057230	5057259
..UP		6927048	6944021	6950640	6952206	
7.0-6.0	5056191	5057141	5057161	5057175	5057232	5057260
..UP		6927050	6950721	6952697	6954217	
8.0-7.0(5/16")		5057144	5057163	5057176	5057234	5057261
..UP		6927051	6927052	6951210	6952200	
9.0-8.0(11/32")		5057145	5057164	5057178	5057235	5057263
..UP		6953019	6952604	6921604	6954118	
10.0-9.0		5057146	5057166	5057179	5057237	5057264
..UP		6951332	6927053	6950641	6952201	
11.0-10.0			5057168	5057181	5057238	5057265
..UP			6927055	6951404	6951867	
12.0-11.0(15/32")			5057169	5057182	5057239	5057266
..UP			6944022	6951209	6946688	
13.0-12.0(1/2")			5057170	5057183	5057240	5057267
..UP			6954657	6951317	6952718	
14.0-13.0				5057184	5057241	5057268
..UP				6951211	6946611	
15.0-14.0				5057185	5057245	5057269
..UP				6921605	6954218	
16.0-15.0(5/8")				5057186	5057247	5057270
..UP				6950642	6951212	
17.0-16.0(21/32")					5057248	5057271
..UP					6954219	
18.0-17.0					5057249	5057273
..UP					6951213	
19.0-18.0					5057250	5057274
..UP					6954220	
20.0-19.0(25/32")					5057251	5057275
..UP					6950710	
21.0-20.0(13/16")						5057276
22.0-21.0						5057277
23.0-22.0						5057284
24.0-23.0(15/16")						5057285
25.0-24.0(31/32")						5057286
26.0-25.0						5057287
ER Collet Set	5083043	5064416	5083046	5064421	5064428	5064429
..UP		5104124	5104125	5104126	5104127	

Bestellbeispiel: / How to order :

Standard-Spannzange / Standard Collet: ER16-1.0 or 5057132

UP Spannzangen / UP Collet: ESX 16-1.0-UP or 6956076

Spannzangensystem ER mit Innenvierkant DIN 6499
Tap Collet ER-System with internal square DIN 6499

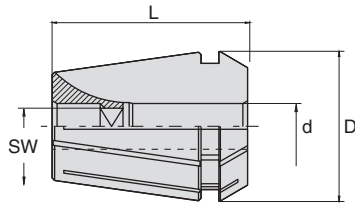

Schaft Shark d (mm) Ø	Innenvierkant Square SW (mm)	426G ESX 16-... D=16.7mm L=27.5mm Ident No.	428G ESX 20-... D=21mm L=31mm Ident No.	430G ESX 25-... D=25.7mm L=34mm Ident No.	470G ESX 32-... D=33mm L=40mm Ident No.	472G ESX 40-... D=41mm L=46mm Ident No.
4.0	3.0	6954588				
4.5	3.4	6951393	6948389	6951218	6952585	
5.5	4.3	6954656	6949764	5073851	5069531	
6.0	4.9	6951392	6948390	6951544	6949997	
7.0	5.5	6947340	6949767	6951797	6950029	
8.0	6.2		6949202	6951214	6949769	6955396
9.0	7.0		6947338	6951216	6946965	6955397
10.0	8.0		6949111	6951215	6949998	9080012
11.0	9.0		6949177	6946167	6946104	6955398
12.0	9.0			6950343	6946106	9074741
14.0	11.0			6951559	6947337	9074742
16.0	12.0			6951399	6948391	9080073
18.0	14.5				6950206	6952207
20.0	16.0				6948392	6948903
22.0	18.0					6949124

Bestellung wie folgt / How to order :
ESX16-6.0x4.9 or 6951392

Spannschlüssel
Wrench



Bild. A
Fig. A



Bild. B
Fig. B

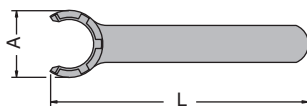

Bild. C
Fig. C

Bezeichnung Designation	für Spannmutter for Clamping Nut	A (mm)	L (mm)	Bild Fig	Ident. No.
E11M	ER11M-DIN 6499	16.8	90	A	6942650
E16M	ER16M-DIN 6499	22.5	110	A	6932510
E20M	ER20M-DIN 6499	29.0	120	A	6934089
E25M	ER25M-DIN 6499	36.0	130	A	6933989
GS25(SW25)	ER16-DIN 6499	44.0	145	B	6927733
E20	ER20-DIN 6499	52.0	170	B	6921607
E25	ER25-DIN 6499	65.0	210	C	6921608
E32	ER32-DIN 6499	75.0	252	C	6921609
E40	ER40-DIN 6499	90.0	292	C	6921610

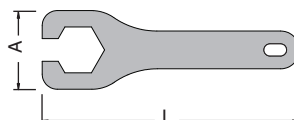
BT MAS 403
ISO7388-2

SK DIN 69871
ISO7388-1

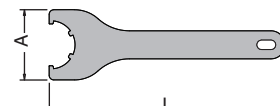
HSK DIN 69893

Zubehör
Accessories

Ersatzteile
Spare Parts

Technische Spezifikationen
Technical Details

Spannmutter ER
Clamping nut ER



Abmessung Size	D	L	G	Bild Fig.	Bezeichnung Designation	Ident No.
1-10	28.0	17.5	M22X1.5	1	ER16	4600340
1-13	34.0	19.0	M25X1.5	1	ER20	5056874
2-16	42.0	20.0	M32X1.5	2	ER25	4600341
2-20	50.0	22.5	M40X1.5	2	ER32	4600342
3-26	63.0	25.5	M50X1.5	2	ER40	4600343

Spannmutter "Mini" ER
Clamping nut "Mini" ER

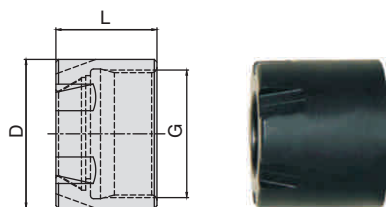

Abmessung Size	D	L	G	Bezeichnung Designation	Ident No.
1-7	16.0	12.0	M13X0.75	ER11M	5033469
1-10	22.0	18.5	M19X1.0	ER16M	6944416
1-13	28.0	19.0	M24X1.0	ER20M	6951224
2-16	35.0	20.0	M30X1.0	ER25M	6955533

Spannmutter ER für Dichtscheiben
Clamping nut ER for sealing discs



Abmessung Size	D	L	G	Bild Fig.	Bezeichnung Designation	Ident No.
1-10	28.0	22.5	M22X1.5	1	ER16-IC	6931372
1-13	34.0	24.0	M25X1.5	1	ER20-IC	6931227
2-16	42.0	25.0	M32X1.5	2	ER25-IC	6941678
2-20	50.0	27.5	M40X1.5	2	ER32-IC	6933897
3-26	63.0	30.5	M50X1.5	2	ER40-IC	6948425

DS/ER Dichtscheiben für ER/ESX-Spannzange DIN6499-B
 DS/ER Sealing disc for ER/ESX collet DIN6499-B

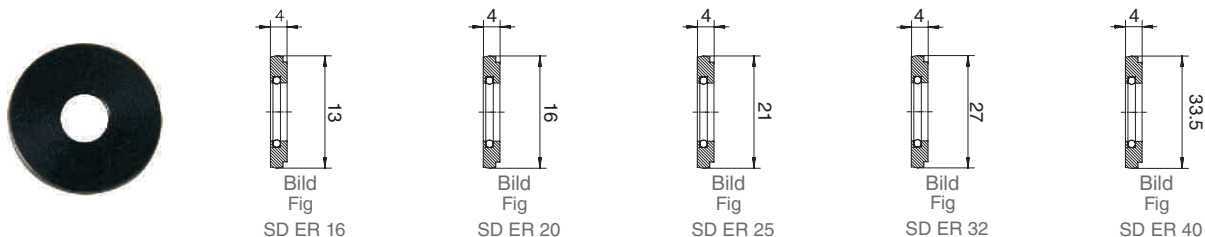

Dichtebereich Sealing Range mm	Id. No. DS/ER 16 (bxa) 4x13 mm	Id. No. DS/ER 20 (bxa) 4x16 mm	Id. No. DS/ER 25 (bxa) 4x21 mm	Id. No. DS/ER 32 (bxa) 4x27 mm	Id. No. DS/ER 40 (bxa) 4x33,5 mm
3.0-2.5	6953629	6954178	6954181	6954194	6954264
3.5-3.0	6954176	6948385	6947674	6954195	6954265
4.0-3.5	6952696	6953235	6954182	6954112	6954266
4.5-4.0	6944324	6948386	6954183	6954196	6954267
5.0-4.5	6952972	6953236	6954184	6954113	6954268
5.5-5.0	6954177	6952104	6954185	6954197	6954269
6.0-5.5	6931371	6943901	6953215	6948674	6954270
6.5-6.0	6943060	6953031	6954186	6954198	6954271
7.0-6.5	6940533	6950178	6943420	6953637	6954272
7.5-7.0	6952195	6953237	6943421	6954199	6954273
8.0-7.5	6941539	6946991	6943419	6949999	6952197
8.5-8.0	6946898	6953238	6952198	6954200	6954274
9.0-8.5	6941992	6947339	6941679	6949298	6954275
9.5-9.0	6946897	6954179	6946744	6954201	6954276
10.0-9.5	6942300	6931347	6943423	6948675	6952199
10.5-10.0		6952196	6954187	6952918	6954277
11.0-10.5		6944294	6943534	6948387	6954278
11.5-11.0		6953239	6954188	6951274	6954279
12.0-11.5		6943902	6943424	6946689	6954280
12.5-12.0		6954180	6954189	6951275	6954281
13.0-12.5		6947968	6948123	6952973	6954282
13.5-13.0			6954190	6954202	6954283
14.0-13.5			6943342	6946613	6954284
14.5-14.0			6954191	6954203	6954285
15.0-14.5			6954192	6954204	6954114
15.5-15.0			6954193	6954205	6954286
16.0-15.5			6943422	6946822	6946054
16.5-16.0				6954206	6954287
17.0-16.5				6954207	6954288
17.5-17.0				6954208	6954289
18.0-17.5				6946002	6946120
18.5-18.0				6954209	6952210
19.0-18.5				6954210	6954115
19.5-19.0				6954211	6954290
20.0-19.5				6933868	6952971
20.5-20.0					6954291
21.0-20.5					9071745
21.5-21.0					6954292
22.0-21.5					6949887
22.5-22.0					6952212
23.0-22.5					9071747
23.5-23.0					6954293
24.0-23.5					9071748
24.5-24.0					6954294
25.0-24.5					6948426
25.5-25.0					6954295
26.0-25.5					9072720

BT MAS 403
ISO7388-2

SK DIN 69871
ISO7388-1

HSK DIN 69893

Zubehör
Accessories

Ersatzteile
Spare Parts

Technische Spezifikationen
Technical Details

Anzugsbolzen DIN 69872 A+B
 Pull stud DIN 69872 A+B

Type A (Mit Durchgangsbohrung, ohne O-Ring)
 Type A (With through hole, without O-ring)

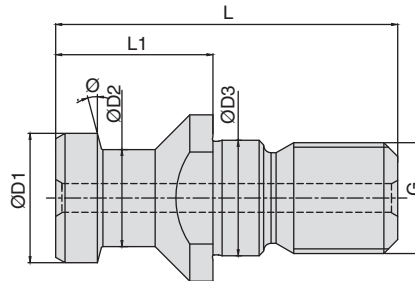

G	ØD1 (mm)	ØD2 (mm)	ØD3 (mm)	L (mm)	L1 (mm)	Ø	Bezeichnung Designation	Ident No.
M12	13.0	9.0	13.0	44.0	24.0	15°	BN 164 - SK 30	6733614
M16	19.0	14.0	17.0	54.0	26.0	15°	BN 164 - SK 40	6733615
M24	28.0	21.0	25.0	74.0	34.0	15°	BN 164 - SK 50	6733616

Type B (Ohne Durchgangsbohrung inkl. O-Ring)
 Type B (without through hole, incl. O-ring)

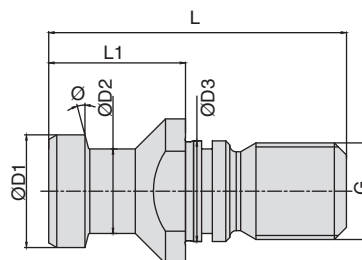

G	ØD1 (mm)	ØD2 (mm)	ØD3 (mm)	L (mm)	L1 (mm)	Ø	Bezeichnung Designation	Ident No.
M16	19.0	14.0	17.0	54.0	26.0	15°	BN 164B - SK 40	5056290
M24	28.0	21.0	25.0	74.0	34.0	15°	BN 164B - SK 50	5056292

Anzugsbolzen MAS BT A+B
Pull stud MAS BT A+B

Type A (Ohne Durchgangsbohrung, ohne O-Ring)
Type A (Without through hole, without O-ring)

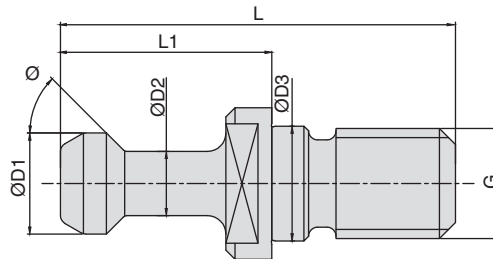

G	ØD1 (mm)	ØD2 (mm)	ØD3 (mm)	L (mm)	L1 (mm)	Ø	Bezeichnung Designation	Ident No.
M12	11.0	7.0	12.5	43.0	23.0	45°	BN 164 - BT 30	6733617
M16	15.0	10.0	17.0	60.0	35.0	45°	BN 164 - BT 40	6733618
M24	23.0	17.0	25.0	85.0	45.0	45°	BN 164 - BT 50	6733619
M12	11.0	7.0	12.5	43.0	23.0	60°	BN 164 - BT 30-60	4600614
M16	15.0	10.0	17.0	60.0	35.0	60°	BN 164 - BT 40-60	4600882
M24	23.0	17.0	25.0	85.0	45.0	60°	BN 164 - BT 50-60	4601402
M16	15.0	10.0	17.0	60.0	35.0	90°	BN 164 - BT 40-90	4600959
M24	23.0	17.0	25.0	85.0	45.0	90°	BN 164 - BT 50-90	4601404

Type B (mit Durchgangsbohrung inkl. O-Ring)
Type B (with through hole, incl. O-ring)

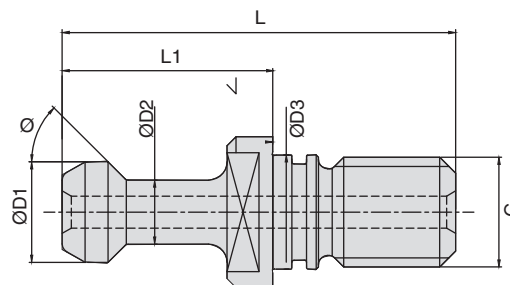

G	ØD1 (mm)	ØD2 (mm)	ØD3 (mm)	L (mm)	L1 (mm)	Ø	Bezeichnung Designation	Ident No.
M12	11.0	7.0	12.5	43.0	23.0	45°	BN 164B - BT 30	4600613
M16	15.0	10.0	17.0	60.0	35.0	45°	BN 164B - BT 40	4600957
M24	23.0	17.0	25.0	85.0	45.0	45°	BN 164B - BT 50	4601460
M12	11.0	7.0	12.5	43.0	23.0	60°	BN 164B - BT 30-60	5084973
M16	15.0	10.0	17.0	60.0	35.0	60°	BN 164B - BT 40-60	4600958
M24	23.0	17.0	25.0	85.0	45.0	60°	BN 164B - BT 50-60	4601461
M16	15.0	10.0	17.0	60.0	35.0	90°	BN 164B - BT 40-90	5084974
M24	23.0	17.0	25.0	85.0	45.0	90°	BN 164B - BT 50-90	4602462

BT MAS 403
ISO7388-2

SK DIN 69871
ISO7388-1

HSK DIN 69893

Zubehör
Accessories

Ersatzteile
Spare Parts

Technische Spezifikationen
Technical Details

Spannzangenfutter Typ ER Zylinderschaft
Collet chuck Type ER With Cylinder Shank



Bild 1
Fig. 1



Bild 2
Fig. 2

Abmessung Size	Spannzange Collet Type	Bereich Range	D (mm)	L (mm)	L1 (mm)	G	Bild Fig	Kühlmittelezufuhr Coolant supply	Bezeichnung Designation	Ident No.
CYL 8	ER 11	1-7	16	56	82.5		1	Form "AD"	WCCH/ER11M-56/CYL8	5056876
CYL 10	ER 16	1-10	22	60	98.5		1	Form "AD"	WCCH/ER16M-60/CYL10	5056879
CYL 12	ER 11	1-7	16	80	106.5		1	Form "AD"	WCCH/ER11M-80/CYL12	5056880
CYL 16	ER 11	1-7	16	100	121.0	M6	2	Form "AD"	WCCH/ER11M-100/CYL16	5056881
CYL 16	ER 16	1-10	22	60	98.5	M8	2	Form "AD"	WCCH/ER16M-60/CYL16	5056882
CYL 16	ER 20	1-13	28	100	142.5	M8	2	Form "AD"	WCCH/ER20M-100/CYL16	5056884
CYL 20	ER 16	1-10	22	100	138.5	M10	2	Form "AD"	WCCH/ER16M-100/CYL20	5056885

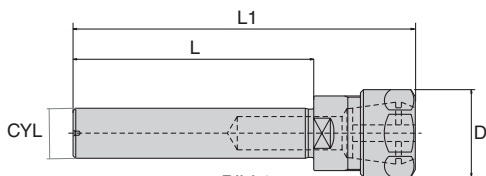
Spannschlüssel DIN 6368
Spanner to DIN 6368

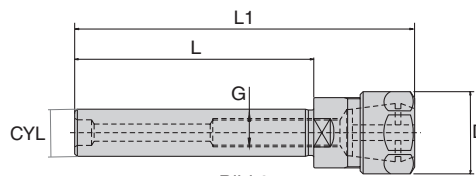
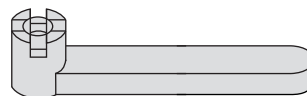

d (mm) (für Größe) (for Size)	Bezeichnung Designation	Ident No.
16	DIN6368-16	5056946
22	DIN6368-22	6942963
27	DIN6368-27	6942916
32	DIN6368-32	6942917
40	DIN6368-40	6950689

Kühlmittelrohr für HSK-Spannfutter. Zur Kühlmittelübergabe bei
HSK-Werkzeugen inkl. Runddichtung DIN 3770 und Überwurfmutter
Coolant tube for HSK chuck
For coolant transfer in HSK tools incl. round gasket DIN 3770 and union nut

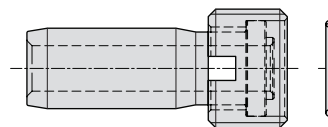

HSK-Größen HSK Size	Bezeichnung Designation	Ident No.
HSK 32	UE4/HSK32	5064893
HSK 40	UE4/HSK40	5028425
HSK 50	UE4/HSK50	5028426
HSK 63	UE4/HSK63	5025376
HSK 80	UE4/HSK80	5028427
HSK 100	UE4/HSK100	5028428

Montageschlüssel für Kühlmittelrohr
Installation wrench for coolant pipe

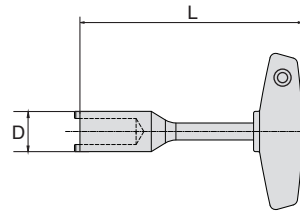

HSK-Größen HSK Size	D (mm)	L (mm)	Ident No.
HSK 32	8.5	115	6738740
HSK 40	10.5	115	6738741
HSK 50	14.5	115	6738422
HSK 63	16.5	136	6738421
HSK 80	18.5	136	6738095
HSK 100	22.0	136	6738303

Spannschlüssel
Wrench

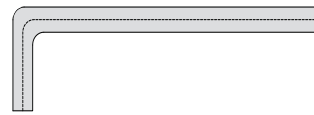

d (mm) (für Größen / for Size)	Bezeichnung Designation	Ident No.
16	SW6	6737650
22	SW8	6737651
27	SW10	6737652
32	SW14	6737654
40	SW17	6737655

BT MAS 403
ISO7388-2

SK DIN 69871
ISO7388-1

HSK DIN 69893

Zubehör
Accessories

Ersatzteile
Spare Parts

Technische Spezifikationen
Technical Details

Ersatzteile für Hochleistungsfräserspannfutter
Spare Parts for Hi-power milling chuck

Zylindrische Spannzange mit Längennachstellung
Adjustable Straight Collet

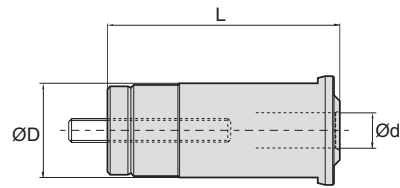

D (mm)	d (mm)	L (mm)	N/W (kg)	Bezeichnung Designation	Ident No.
20	6	63	0.15	WSC20-06	5056814
20	8	63	0.15	WSC20-08	5056817
20	10	63	0.15	WSC20-10	5056818
20	12	63	0.15	WSC20-12	5056819
20	16	63	0.15	WSC20-16	5056820
25	6	73	0.15	WSC25-06	5056821
25	8	73	0.15	WSC25-08	5056822
25	10	73	0.15	WSC25-10	5056823
25	12	73	0.15	WSC25-12	5056824
25	16	73	0.15	WSC25-16	5056825
25	18	73	0.15	WSC25-18	5056827
25	20	73	0.15	WSC25-20	5056828
32	6	79	0.35	WSC32-06	5056829
32	8	79	0.35	WSC32-08	5056830
32	10	79	0.35	WSC32-10	5056831
32	12	79	0.35	WSC32-12	5056832
32	16	79	0.35	WSC32-16	5056833
32	18	79	0.35	WSC32-18	5056834
32	20	79	0.35	WSC32-20	5056835
32	25	79	0.35	WSC32-25	5056836

Spannschlüssel
Wrench



(für Größen) (For size)	N/W (kg)	Bezeichnung Designation	Ident No.
WHPMC 20	0.15	C-20	5056838
WHPMC 25	0.15	C-25	5056839
WHPMC 32	0.30	C-32	5056840

Rollspannschlüssel (für schlanke Hochleistungsfräserspannfutter)
Friction wrench (for Slim Hi-Power Milling Chuck)

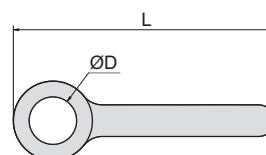

Größe Size	d (mm)	D (mm)	L (mm)	Bezeichnung Designation	Ident No.
S06, S08	06	25	135	FW-D25	5106044
S10, S12	12	30	150	FW-D30	5097511
S16	16	38	180	FW-D38	5097513
S20	20	44	210	FW-D44	5097514

Ersatzteile für Hydrodehnspannfutter
Spare Parts for Hydraulic expansion chuck

WHC - Reduzierbuchsen
WHC - Reduction sleeves

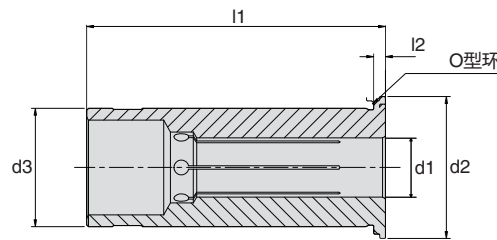

d1 (mm)	d2 (mm)	d3 (mm)	l1 (mm)	l2 (mm)	Innere Kühlmittelzufuhr / Internal coolant supply Bezeichnung Designation	Ident No.
3	19	12	45.0	2	WHC12-3	9142752
4	19	12	45.0	2	WHC12-4	9142753
5	19	12	45.0	2	WHC12-5	9142754
6	19	12	45.0	2	WHC12-6	9142755
8	19	12	45.0	2	WHC12-8	9142756
3	29	20	50,5	2	WHC20-3	9142758
4	29	20	50,5	2	WHC20-4	9142779
5	29	20	50,5	2	WHC20-5	9142780
6	29	20	50,5	2	WHC20-6	9142781
7	29	20	50,5	2	WHC20-7	9142782
8	29	20	50,5	2	WHC20-8	9142784
9	29	20	50,5	2	WHC20-9	9142785
10	29	20	50,5	2	WHC20-10	9142786
11	29	20	50,5	2	WHC20-11	9142787
12	29	20	50,5	2	WHC20-12	9142788
13	29	20	50,5	2	WHC20-13	9142799
14	29	20	50,5	2	WHC20-14	9142800
15	29	20	50,5	2	WHC20-15	9142801
16	29	20	50,5	2	WHC20-16	9142802
6	39	32	60,5	3	WHC32-6	9142804
8	39	32	60,5	3	WHC32-8	5069815
10	39	32	60,5	3	WHC32-10	9142809
12	39	32	60,5	3	WHC32-12	9142810
14	39	32	60,5	3	WHC32-14	9142811
16	39	32	60,5	3	WHC32-16	9142812
18	39	32	60,5	3	WHC32-18	9142813
20	39	32	60,5	3	WHC32-20	9142814
25	39	32	60,5	3	WHC32-25	9142815

• Bei innerer Kühlmittelzufuhr: Bund geschlossen, Kühlmitteldicht bis max. 80 bar • For internal coolant supply: Closed collar, coolant proof up to max. 80 bar

WHC/WZ - Ausziehwerkzeug für Reduzierbuchsen
WHC/WZ - Sleeve remover

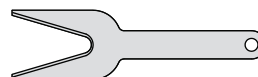

Bezeichnung Designation	Ident No.
HGR/WZ	9142854

Ersatzteile für Aufnahmen - Einschraubfräser
Spare Parts for Chucks - Threaded milling heads

Einschraubfräser Verlängerung
Threaded arbor extensions

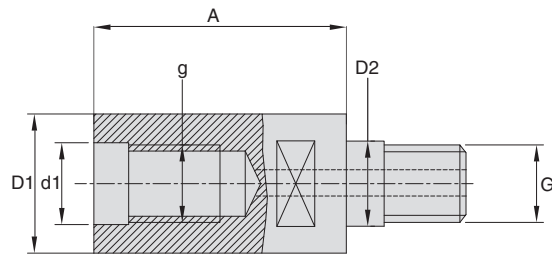

g / G (mm)	d1 / D2 (mm)	A (mm)	D1 (mm)	Bezeichnung Designation	Ident No.
M8	8.5	40	13,8	WTA/M8-40/M8	5056841
M8	8.5	60	13,8	WTA/M8-60/M8	5056842
M10	10.5	40	18,0	WTA/M10-40/M10	5056843
M10	10.5	60	18,0	WTA/M10-60/M10	5056844
M12	12.5	40	21,0	WTA/M12-40/M12	5056845
M12	12.5	60	21,0	WTA/M12-60/M12	5056846
M16	17.0	40	29,0	WTA/M16-40/M16	5056847
M16	17.0	60	29,0	WTA/M16-60/M16	5056848

Einschraubfräser Reduzierung
Threaded arbor reductions

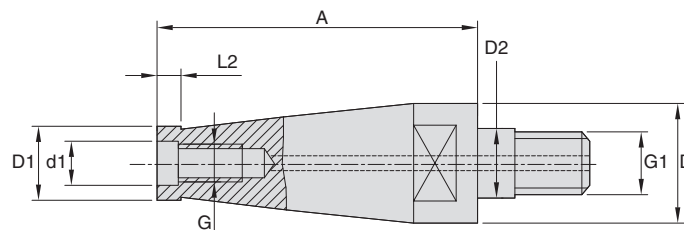

G (mm)	G1 (mm)	D2 (mm)	d1 (mm)	A (mm)	D1 (mm)	D (mm)	L2 (mm)	Bezeichnung Designation	Ident No.
M5	M8	8,5	5,5	40	10,0	13,0	6	WTA/M5-40/M8	5056849
M8	M10	10,5	8,5	40	13,8	18,0	6	WTA/M8-40/M10	5056850
M8	M12	12,5	8,5	60	13,8	21,0	6	WTA/M8-60/M12	5056851
M10	M12	12,5	10,5	40	18,0	21,0	6	WTA/M10-40/M12	5056853
M10	M16	17,0	10,5	60	18,0	29,0	6	WTA/M10-60/M16	5056854
M12	M16	17,0	12,5	40	21,0	29,0	6	WTA/M12-40/M16	5056855

Super collet Spannzangen - Zubehör für Super collet Spannzangenfutter
 Super collet - Spare parts for Super collet chuck

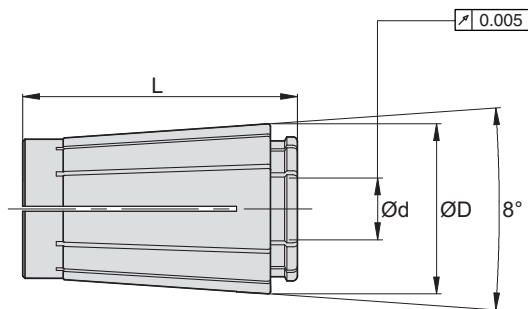

Spannzange Collet Type	Bereich Range	d (mm)	L (mm)	D (mm)	Ident No.
SC06-2.0	1.75-2.00	2.0	25	11	5103501
SC06-2.5	2.25-2.50	2.5	25	11	5103503
SC06-3.0	2.75-3.00	3.0	25	11	5103504
SC06-3.5	3.00-3.50	3.5	25	11	5103505
SC06-4.0	3.50-4.00	4.0	25	11	5103506
SC06-4.5	4.00-4.50	4.5	25	11	5103507
SC06-5.0	4.50-5.00	5.0	25	11	5103511
SC06-5.5	5.00-5.50	5.5	25	11	5103512
SC06-6.0	5.50-6.00	6.0	25	11	5103513
SC10-2.0	1.75-2.00	2.0	30	16	5103572
SC10-2.5	2.25-2.50	2.5	30	16	5103574
SC10-3.0	2.75-3.00	3.0	30	16	5103575
SC10-3.5	3.00-3.50	3.5	30	16	5103576
SC10-4.0	3.50-4.00	4.0	30	16	5103577
SC10-4.5	4.00-4.50	4.5	30	16	5103578
SC10-5.0	4.50-5.00	5.0	30	16	5103579
SC10-5.5	5.00-5.50	5.5	30	16	5103580
SC10-6.0	5.50-6.00	6.0	30	16	5103581
SC10-6.5	6.00-6.50	6.5	30	16	5103582
SC10-7.0	6.50-7.00	7.0	30	16	5103583
SC10-7.5	7.00-7.50	7.5	30	16	5103584
SC10-8.0	7.50-8.00	8.0	30	16	5103585
SC10-8.5	8.00-8.50	8.5	30	16	5103586
SC10-9.0	8.50-9.00	9.0	30	16	5103587
SC10-9.5	9.00-9.50	9.5	30	16	5103588
SC10-10.0	9.50-10.00	10.0	30	16	5103589
SC13-3.0	2.75-3.00	3.0	39	20	5103654
SC13-3.5	3.00-3.50	3.5	39	20	5103655
SC13-4.0	3.50-4.00	4.0	39	20	5103656
SC13-4.5	4.00-4.50	4.5	39	20	5103657
SC13-5.0	4.50-5.00	5.0	39	20	5103658
SC13-5.5	5.00-5.50	5.5	39	20	5103659
SC13-6.0	5.50-6.00	6.0	39	20	5103660
SC13-6.5	6.00-6.50	6.5	39	20	5103661
SC13-7.0	6.50-7.00	7.0	39	20	5103662
SC13-7.5	7.00-7.50	7.5	39	20	5103663
SC13-8.0	7.50-8.00	8.0	39	20	5103664
SC13-8.5	8.00-8.50	8.5	39	20	5103665
SC13-9.0	8.50-9.00	9.0	39	20	5103667
SC13-9.5	9.00-9.50	9.5	39	20	5103668
SC13-10.0	9.50-10.00	10.0	39	20	5103669
SC13-10.5	10.00-10.50	10.5	39	20	5103670
SC13-11.0	10.50-11.00	11.0	39	20	5103671
SC13-11.5	11.00-11.50	11.5	39	20	5103672
SC13-12.0	11.50-12.00	12.0	39	20	5103673
SC13-12.5	12.00-12.50	12.5	39	20	5103674
SC13-13.0	12.50-13.00	13.0	39	20	5103675

BT MAS 403
ISO7388-2

SK DIN 69871
ISO7388-1

HSK DIN 69893

Zubehör
Accessories

Ersatzteile
Spare Parts

Technische Spezifikationen
Technical Details

Super collet Spannzangen - Zubehör für Super collet Spannzangenfutter
 Super collet - Spare parts for Super collet chuck

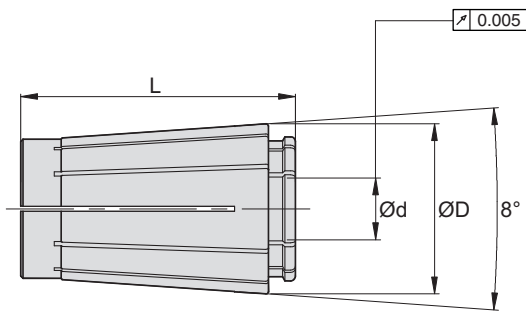

Spannzange Collet Type	d (mm)	L (mm)	D (mm)	Ident No.
SC16-3.0	3.0	45	25	5103676
SC16-4.0	4.0	45	25	5103678
SC16-5.0	5.0	45	25	5103680
SC16-6.0	6.0	45	25	5103681
SC16-8.0	8.0	45	25	5103682
SC16-10.0	10.0	45	25	5103683
SC16-12.0	12.0	45	25	5103684
SC16-16.0	16.0	45	25	5103685
SC20-6.0	6.0	50	30	5103952
SC20-8.0	8.0	50	30	5103953
SC20-10.0	10.0	50	30	5103954
SC20-12.0	12.0	50	30	5103970
SC20-14.0	14.0	50	30	5103972
SC20-16.0	16.0	50	30	5103974
SC20-18.0	18.0	50	30	5103976
SC20-20.0	20.0	50	30	5103977
SC25-6.0	6.0	57	36	5104103
SC25-8.0	8.0	57	36	5104104
SC25-10.0	10.0	57	36	5104105
SC25-12.0	12.0	57	36	5104106
SC25-16.0	16.0	57	36	5104107
SC25-20.0	20.0	57	36	5104108
SC25-25.0	25.0	57	36	5104109

Rollspannschlüssel
 Friction Wrench

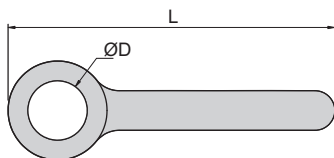

Bezeichnung Designation	Spannzange Collet Type	D (mm)	L (mm)	Ident No.
FW-D19.5	SCS06-FN	19.5	130	5102205
FW-D27.1	SCS10-FN	27.1	135	5103190
FW-D33	SCS13-FN	33.0	160	5102206
FW-D40	SCS16-FN	40.0	180	5102207
FW-D48	SCS20-FN	48.0	210	5103191
FW-D55	SCS25-FN	55.0	300	5102209

Spannmutter für Rollspannschlüssel (für Super collet Spannzangenfutter)
Friction Nut (for Super collet chuck)

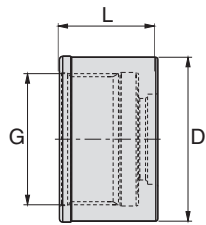

Spannzange Collet Type	Bereich Range	ØD (mm)	L (mm)	G (mm)	Ident No.
SCN06-FN	2.0-6.0	19.5	15	M15.5x1	5102199
SCN10-FN	2.0-10.0	27.1	17	M21.5x1	5102200
SCN13-FN	3.0-13.0	33.0	21	M27x1	5102201
SCN16-FN	4.0-16.0	40.0	24	M32x1.5	5102202
SCN20-FN	6.0-20.0	48.0	24	M40x1	5102203
SCN25-FN	16.0-25.0	55.0	30	M45x1.5	5102204

Spannmutter (für Super collet Spannzangenfutter)
Clamping Nut (for Super collet chuck)

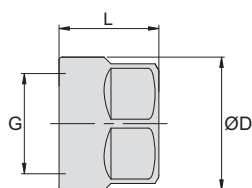

Fig. A

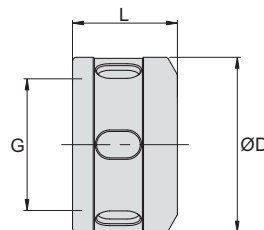

Fig. B

Spannzange Collet Type	Bereich Range	ØD (mm)	L (mm)	G (mm)	Fig.	Ident No.
SCN06	2.0-6.0	20.0	15	M15.5x1	A	5104250
SCN10	2.0-10.0	28.0	17	M21.5x1	A	5104251
SCN13	3.0-13.0	33.0	21	M27x1	B	5104252
SCN16	4.0-16.0	40.0	24	M32x1.5	B	5104253
SCN20	6.0-20.0	48.5	24	M40x1	B	5104254
SCN25	16.0-25.0	55.0	30	M45x1.5	B	5104255

Spannschlüssel
Wrench

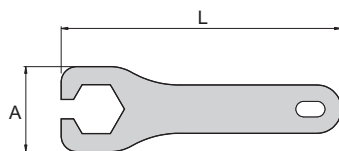

Fig. A

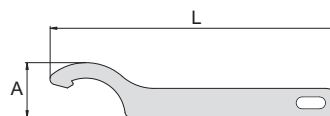

Fig. B

Spannzange Collet Type	A (mm)	L (mm)	Fig.	Ident No.
SCS06	35.2	130	A	5104257
SCS10	44.0	145	A	5104258
SCS13	24.7	140	B	5104261
SCS16	28.3	150	B	5104262
SCS20	32.5	180	B	5104263
SCS25	37.8	200	B	5104264

BT MAS 403
ISO7388-2

SK DIN 69871
ISO7388-1

HSK DIN 69893

Zubehör
Accessories

Ersatzteile
Spare Parts

Technische Spezifikationen
Technical Details

Montagevorrichtung WMV 4 x 90° arretierbar
 Assembly Device WMV 4 x 90° lockable



Bezeichnung Designation	Ident No.
WMV-4x90	5080506

Werkzeugaufnahme für WMV SK (DIN, MAS-BT, CAT)
 Toolholder for WMV ISO (DIN, MAS-BT. CAT)



Bezeichnung Designation	Ident No.
WMV-4x90-SK/ISO30	5080385
WMV-4x90-SK/ISO40	5080502
WMV-4x90-SK/ISO50	5080504

Werkzeugaufnahme für WMV HSK-A
 Toolholder for WMV HSK-A



Bezeichnung Designation	Ident No.
WMV-4x90-HSK-A32	5080388
WMV-4x90-HSK-A40	5080389
WMV-4x90-HSK-A50	5080390
WMV-4x90-HSK-A63	5080391
WMV-4x90-HSK-A80	5080394
WMV-4x90-HSK-A100	5080395

Werkzeugaufnahme für WMV HSK-C / E
Toolholder for WMV HSK-C / E



Bezeichnung Designation	Ident No.
WMV-4x90-HSK-C/E25	5080397
WMV-4x90-HSK-C/E32	5080398
WMV-4x90-HSK-C/E40	5080400
WMV-4x90-HSK-C/E50	5080403
WMV-4x90-HSK-C/E63	5080405
WMV-4x90-HSK-C/E80	5080406
WMV-4x90-HSK-C/E100	5080408

BT MAS 403
ISO7388-2

SK DIN 69871
ISO7388-1

Werkzeugaufnahme für WMV PSC (passend für Capto)
Toolholder for WMV PSC (suitable for Capto)



Bezeichnung Designation	Ident No.
WMV-4x90-PSC32	5080409
WMV-4x90-PSC40	5080410
WMV-4x90-PSC50	5080411
WMV-4x90-PSC63	5080412
WMV-4x90-PSC80	5080414

HSK DIN 69893

Zubehör
Accessories

Ersatzteile
Spare Parts

Technische Spezifikationen
Technical Details

Micro Spannfutter Verlängerungen MCE

Micro chuck extensions MCE

Sehr schlanke Ausführungen für schwer zugänglich Bearbeitungszonen. Zum Prozesssicheren Spannen aller Schafttoleranzen von h4 bis h9 von Durchmesser 1 mm bis 6 mm.

Die Spannfutterverlängerungen sind mit einem h6 Schaft ausgeführt und sind damit ideal zum Einschumpfen in ThermoGrip Schrumpffutter.

Durch die zentrale Spannschraube in Verbindung mit dem flachen Kegelwinkel wird eine sehr hohe Rundlaufgenauigkeit erreicht.

Bedienung von hinten durch den mitgelieferten Sechskantschlüssel.

Very slim design for working areas with access difficulties. Reliable clamping of all shank tolerances from h4 to h9 for diameter 1 mm to 6 mm. The micro chuck extensions are manufactured with an h6 shank. Due to the central clamping screw in combination with a flat cone angle, a very high run-out accuracy is achieved. Operation from behind using the allen key provided.

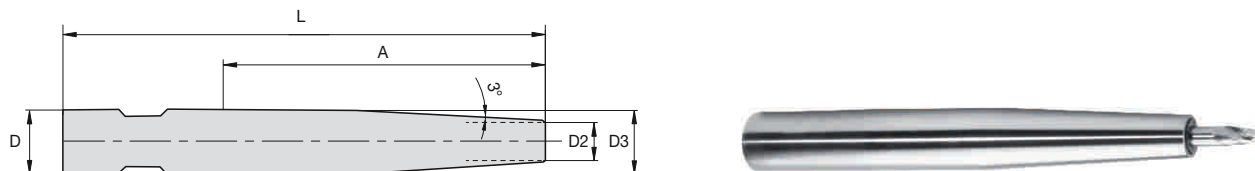

D1 [mm]	A [mm]	L [mm]	D [mm]	D2 [mm]	D3 [mm]	L1 [mm]	Bezeichnung Designation	Ident No.
1-6	50	100	14	13	14	29.2	MCE06-100/14	5053283
1-6	100	150	14	13	14	29.2	MCE06-150/14	5053284
1-6	100	190	14	13	14	29.2	MCE06-190/14	5053285
1-6	50	100	20	13	20	29.2	MCE06-100/20	5053286
1-6	100	150	20	13	20	29.2	MCE06-150/20	5053287

Spannzangen für MCE Verlängerungen

Collets for MCE extensions



Standard Ausführung Standard version			Dichtende Ausführung Sealing version		
Werkzeug Ø Tool Ø	Bezeichnung Designation	Ident No.	Werkzeug Ø Tool Ø	Bezeichnung Designation	Ident No.
1,0	MCC06-1	5053288	1,0	MCC06-1/S	5053295
2,0	MCC06-2	5053289	2,0	MCC06-2/S	5053296
3,0	MCC06-3	5053291	3,0	MCC06-3/S	5053297
4,0	MCC06-4	5053292	4,0	MCC06-4/S	5053298
5,0	MCC06-5	5053293	5,0	MCC06-5/S	5053299
6,0	MCC06-6	5053294	6,0	MCC06-6/S	5053300

Spanndurchmesser für Werkzeuge Ø: 2,5 | 2,8 | 3,5 | 4,5 ab Stückzahl 10 erhältlich
Clamping diameter for tool Ø: 2,5 | 2,8 | 3,5 | 4,5 available from quantities of 10

Drehmomentschlüssel für MCE (Auslösemoment 1,5 - 3 Nm)

Torque wrench for MCE (unclamping torque 1,5 - 3 Nm)



Bezeichnung Designation	Ident No.
MCT06-4x220	5053305

für Weldon und Whistle Notch for Weldon & whistle notch holder	E2
für Kombi und Aufsteckfräserdorne for Combi & shell mill holder	E3 - E4
für Morse-Kegel mit Anzugsgewinde for Morse taper with thread	E5 - E6
für Zwischenhülsen for Reduction sleeves	E7

BT MAS 403
ISO7388-2

SK DIN 69871
ISO7388-1

HSK DIN 69893

Zubehör
Accessories

Ersatzteile
Spare Parts

Technische Spezifikationen
Technical Details

Spannschraube für Weldon und Whistle Notch Spannutter DIN 1835 B
 Locking screw for Weldon & Whistle Notch to DIN 1835 B

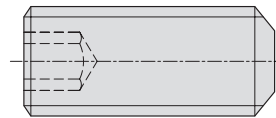

d (mm) (für Größe) (for Size)	Bezeichnung Designation	Ident No.
16*	DIN1835-B-M14X14	5056294
20*	DIN1835-B-M16X12	5056295
25* & 32*	M16X1X10.5	5056296
25*	M16X1X8.5	5056297
32*	DIN1835-B-M20X2X16	5056298
6	DIN1835-B-M6X10	6919658
8	DIN1835-B-M8X10	6919659
10	DIN1835-B-M10X12	6919660
12 & 14	DIN1835-B-M12X16	6919661
16 & 18	DIN1835-B-M14X16	6919662
20	DIN1835-B-M16X16	6924584
25	DIN1835-B-M18X2X20	6919664
32 & 40	DIN1835-B-M20X2X20	6919665

* For short GPL's
 * Für kurze Vorbaulänge

Anschlagschraube durchbohrt für Whistle Notch Aufnahmen
 Adjusting screw with coolant hole for Whistle Notch holder

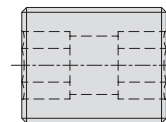

d (mm) (für Größe) (for Size)	Bezeichnung Designation	Ident No.
6	M5x15	5056887
8	M6x15	5056888
10	M8x15	5056889
12 & 14	M10x15	5056891
16 & 18	M12x15	5056893
20	M16x15	5056894
25, 32 & 40	M20x15	5056895

Ersatzteile für Kombi und Aufsteckfräserdorn
Spare parts for Combi & Shell mill holder

Fräseranzugsschraube DIN 6367
Clamping screw to DIN 6367

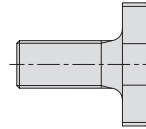

d (mm) (für Größe) (for Size)	Bezeichnung Designation	Ident No.
16	DIN6367-M8	6934073
22	DIN6367-M10	6940383
27	DIN6367-M12	6941541
32	DIN6367-M16	6942757
40	DIN6367-M20	6943111
50	DIN6367-M24	5111255

Mitnehmerring DIN 6366
Drive ring to DIN 6366

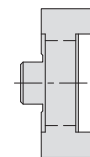

d (mm) (für Größe) (for Size)	Bezeichnung Designation	Ident No.
16	DIN6366-C16	5056898
22	DIN6366-C22	5056900
27	DIN6366-C27	5056901
32	DIN6366-C32	5056903
40	DIN6366-C40	5056904

Passfeder DIN 6885
Parallel key to DIN 6885

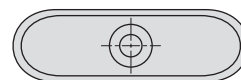

d (mm) (für Größe) (for Size)	Bezeichnung Designation	Ident No.
16	DIN6885-C4x4x20	5056905
22	DIN6885-C6x6x25	5056909
27	DIN6885-C7x7x25	5056610
32	DIN6885-C8x7x28	5056911
40	DIN6885-C10x8x32	5056912

BT MAS 403
ISO7388-2

SK DIN 69871
ISO7388-1

HSK DIN 69893

Zubehör
Accessories

Ersatzteile
Spare Parts

Technische Spezifikationen
Technical Details

Ersatzteile für Kombi und Aufsteckfräserdorn
Spare parts for Combi & Shell mill holder

Gewindestift DIN 913
Threaded stud to DIN 913

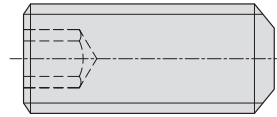

d (mm) (für Größe) (for Size)	Bezeichnung Designation	Ident No.
16	DIN913-M3x3	6914425
22, 27, 32	DIN913-M3x5	6951794
40	DIN913-M3x7	5056913

Paßfeder
Drive keys

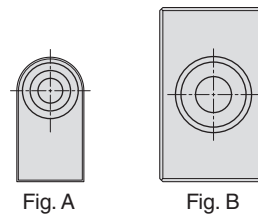

d (mm) (für Größe) (for Size)	Bezeichnung Designation		Ident No.
16	Dia16-8x8x14	Fig. A	5057289
22	Dia22-10x10x17	Fig. A	5057290
27	Dia27-12x14x20	Fig. A	5057291
32	Dia32-14x14x22	Fig. A	5057293
40	Dia40-15.9x16x21	Fig. B	5057294
60	Dia60-25.4x25x31	Fig. B	5057295

Innensechskantschraube DIN 912
Socket head screw to DIN 912

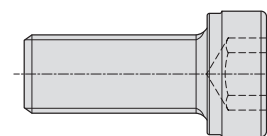

d (mm) (für Größe) (for Size)	Bezeichnung Designation	Ident No.
16	DIN912-M3x8	6914489
22	DIN912-M4x8	6918335
27	DIN912-M4x14	6941122
32	DIN912-M5x13	5056916
40	DIN912-M6x16	6900224
60	DIN912-M12x25	6914503

Ersatzteile für Morse-Kegel mit Anzugsgewinde
Spare Parts for Morse taper with thread

Innensechskantschraube
Socket Head Screw

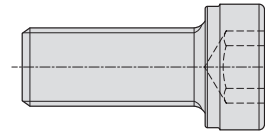

Kegelgröße Taper Size (SK/BT/ISO)	MK	Bezeichnung Designation	Ident No.
40 & 50	1	M6x21	5056917
	2	M10x30	5089591
	3	M12x40	6918327
	4	M16x40	6924372
	5	M20x60	5056918

Rückschlagschraube
Stopper Screw

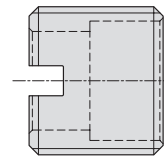

Kegelgröße Taper Size (SK/BT/ISO)	MK	Bezeichnung Designation	Ident No.
40 & 50	1	M16x10	5057297
	2	M16x8	5057299
	3	M20x1.5x10	5057300
	4	M26x1.5x10	5057301
	5	M36x2.5x15	5057305

Gewindestift DIN 913
Threaded stud DIN 913

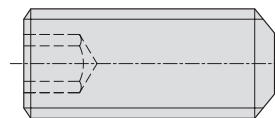

Kegelgröße Taper Size (SK/BT/ISO)	MK	Bezeichnung Designation	Ident No.
40 & 50	1	DIN913-M5x6	6900216
	2	DIN913-M5x6	6900216
	3	DIN913-M5x6	6900216
	4	DIN913-M5x6	6900216
	5	DIN913-M5x6	6900216

BT MAS 403
ISO7388-2

SK DIN 69871
ISO7388-1

HSK DIN 69893

Zubehör
Accessories

Ersatzteile
Spare Parts

Technische Spezifikationen
Technical Details

Ersatzteile für Morse-Kegel mit Anzugsgewinde
Spare Parts for Morse taper with thread

Innensechskantschraube
Socket Head Screw

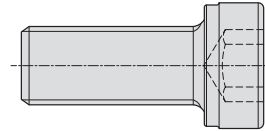

Kegelgröße Taper Size (HSK)	MK	Bezeichnung Designation	Ident No.
A63 & A100	1	M06x20	6914495
	2	M10x30	6933092
	3	M12x30	6922632
	4	M16x45	6933120
	5	DIN912-IC-M20x55	5089579

Rückschlagschraube
Stopper Screw

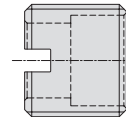

Kegelgröße Taper Size (HSK)	MK	Bezeichnung Designation	Ident No.
A63 & A100	1	M10x1.0x6-LH	5059807
	2	M15x1.5x6-LH	5059811
	3	M20x1.5x6-LH	5059812
	4	M24x1.5x8.5-LH	5059813
	5	M26x2.0x11-LH	5059814

Ersatzteile für Zwischenhülsen
Spare Parts for Reduction Sleeves

Innensechskantschraube
Socket Head Screw

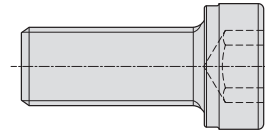

Kegelgröße Taper Size (SK/BT)	Innenkegelgröße Inside Taper	Bezeichnung Designation	Ident No.
SK40/BT40	SK 30	DIN912-M12x40	5089589
SK40/BT40	SK 40	DIN912-M16x60	6929756
SK50/BT50	SK 40	DIN912-M16x50	6912389
SK50/BT50	SK 50	DIN912-M24x85	5056920

BT MAS 403
ISO7388-2

SK DIN 69871
ISO7388-1

Rückschlagschraube
Stopper Screw

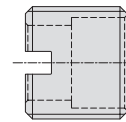

Kegelgröße Taper Size (SK/BT/ISO)	Innenkegelgröße Inside Taper	Bezeichnung Designation	Ident No.
40	30	M18x1.5x10	5057303
	40	M26x1.5x13	5057304
50	40	M26x1.5x13	5057304
	50	M36x2.0x15	5057302

HSK DIN 69893

Zubehör
Accessories

Gewindestift DIN 913
Threaded Stud DIN 913

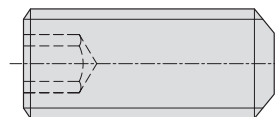

Bezeichnung Designation (SK/BT/ISO)	Ident No.
DIN913-M5x6	6900216

Ersatzteile
Spare Parts

Technische Spezifikationen
Technical Details

Technische Spezifikationen Technical details

Spannmuttern - Betriebsanleitung Clamping Nut - Instructions	F2
Werkzeugschaft DIN 69871 (SK) Tool Shank to DIN 69871 (SK)	F3
Werkzeugschaft JIS B6339 (MAS 403 BT) Tool Shank to JIS B6339 (MAS 403 BT)	F3
Kühlmittelezufuhr – Umbauanleitung Coolant Supply - Instruction for change	F4
Übersicht Werkzeugschäfte DIN 69893 (HSK) Overview tool shanks DIN 69893 (HSK)	F5-F6
Hochleistungsfräserspannfutter - Zusätze und Vorteile Hi-Power Milling Chuck - Features & Advantages	F7-F8
DS/ER Dichtscheibe - Betriebsanleitung DS/ER Sealing disc - Instructions	F9

WICHTIGE BESTELLMHINWEISE / IMPORTANT HINTS

Programmaktualität Im Rahmen der kontinuierlichen Aktualisierung unseres Produktprogrammes nehmen wir nicht nur neue und damit technisch bessere Produkte im Programm auf, sondern führen auch eine intensive Programmbereinigung durch. Es kann also im Einzelfall passieren, dass wir einen von Ihnen bestellten Artikel nicht mehr lagermäßig führen. Sie erhalten dann von uns in der Regel ein technologisch besseres Produkt, mindestens aber eine gleichwertige Alternative. In Zweifelsfällen wird sich unser Verkaufsteam mit Ihnen in Verbindung setzen, um eine für Sie optimale Ausführung zu bestimmen. Durch diese Vorgehensweise ist sichergestellt, dass Sie stets mit Werkzeugen beliefert werden, die technisch auf dem neuesten Stand sind. Eine Verpflichtung zur Lieferung von noch im Katalog oder in der Preisliste abgebildeten Werkzeugen, die intern aber bereits programmbereinigt wurden, übernehmen wir deshalb nicht.

Updating of our product range

In the course of updating our product range, we are not only constantly adding new and technically improved products to our program, but at the same time we are also continually reassessing the product range. In exceptional cases, it is possible that we no longer have the product you order on stock. You will then receive a technically improved product or an equivalent alternative. In any case of doubt, our sales team will contact you in order to determine the optimal version for you. We ensure that you will always get the most updated tools. We therefore do not assume any obligation to supply tools appearing in the catalogue and/or in the price list which have already been adjusted out of the system internally.

Bilz and its partners shall have no liability for indirect, incidental or consequential errors in this catalog.

Nachdruck, auch auszugsweise, ist nur mit unserer Zustimmung gestattet. Alle Rechte vorbehalten. Irrtümer, Satz- oder Druckfehler berechtigen nicht zu irgendwelchen Ansprüchen. Abbildungen, Ausführungen und Maße entsprechen dem neuesten Stand bei Herausgabe dieser Druckschrift. Technische Änderungen müssen vorbehalten sein. Die bildliche Darstellung der Produkte muss nicht in jedem Falle und in allen Einzelheiten dem tatsächlichen Aussehen entsprechen.

This publication may not be reprinted in whole or part without our permission. All rights reserved. No rights may be derived from any errors in content or from typographical or typesetting errors. Diagrams, features, and dimensions represent the current status of the date of issue on this catalog. We reserve the right to make technical changes. The visual appearance of the products may not necessarily correspond to the actual appearance in all cases or in every detail.

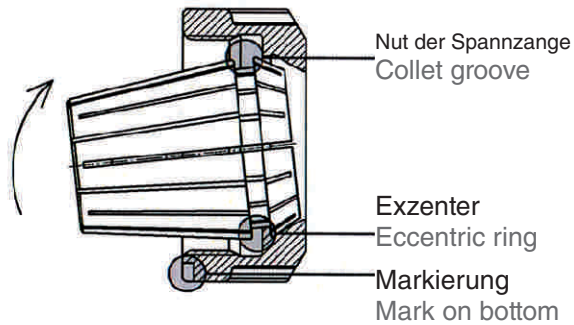

Montageanleitung

Nut der Spannzange an der markierten Stelle in den Exzentering der Spannmutter einhängen. Spannzange in entgegengesetzte Richtung kippen, bis diese deutlich hörbar einrastet. Werkzeug einsetzen. Spannmutter mit der eingerasteten Spannzange auf das Gewinde des Halters schrauben. Wir empfehlen, die Spannmutter mit einem Drehmomentschlüssel anzuziehen.

Assembling Collet:

Insert groove of the collet into eccentric ring of the clamping nut at the mark on the bottom of the nut. Push collet in the direction of the arrow until it clicks in. Insert tool. Screw nut with collet onto tool holder.

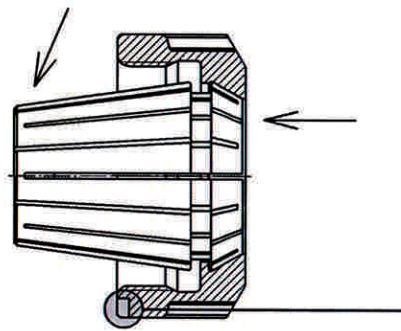

Demontage

Nach dem Abschrauben vom Halter auf die Frontseite der Spannzange drücken und gleichzeitig die Spannzange durch seitlichen Druck auf den hinteren Teil, gegenüber der Markierung, aus der Einrastung der Mutter heraus drücken.

Removing Collet:

After the nut is unscrewed from the toolholder, press on the face of the collet while simultaneously pushing sideways on the back of the collet opposite the mark until it disengages from the clamping nut.

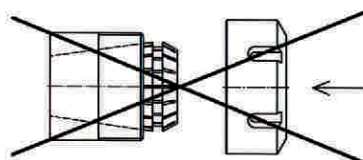

! Eine falsche Handhabung beeinträchtigt den Rundlauf der Spannzange und kann die Spannmutter beschädigen.

Nur Spannmuttern mit richtig eingerasteter Spannzange in den Spannzangenhalter einsetzen!

! Improper assembly can permanently damage the concentricity of the collet and may result in the destruction of the clamping nut.

Only mount nuts with correctly inserted collets! Never place the collet into the holder without first assembling into the nut.

Werkzeugschaft
Tool Shank

DIN 69871 (SK)

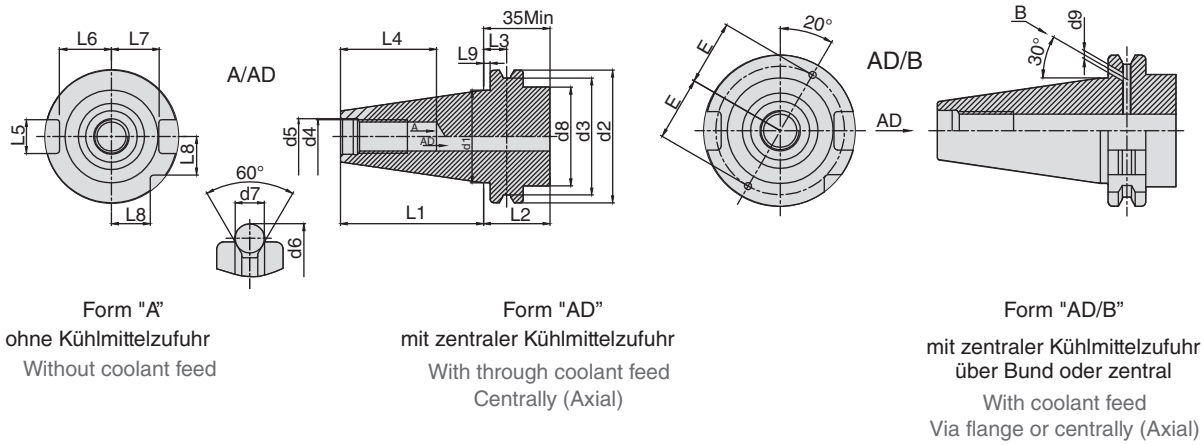

Size	d1	d2	d3	d4	d5	d6	d7	d8	d9	L1	L2	L3	L4	L5	L6	L7	L8	E
30	31,75	50,00	44,30	M12	13	59,30	7	45max	–	47,80	19,1	11,1	30,0min	16,1	19,0	16,4	15,0	-
40	44,45	63,50	56,25	M16	17	72,30	7	50max	4	68,40	19,1	11,1	45,0min	16,1	25,0	22,8	18,5	27
50	69,85	97,50	91,25	M24	25	107,25	7	80max	6	101,75	19,1	11,1	55,0min	25,7	37,1	35,5	30,0	42

JIS B6339 (MAS 403 BT)

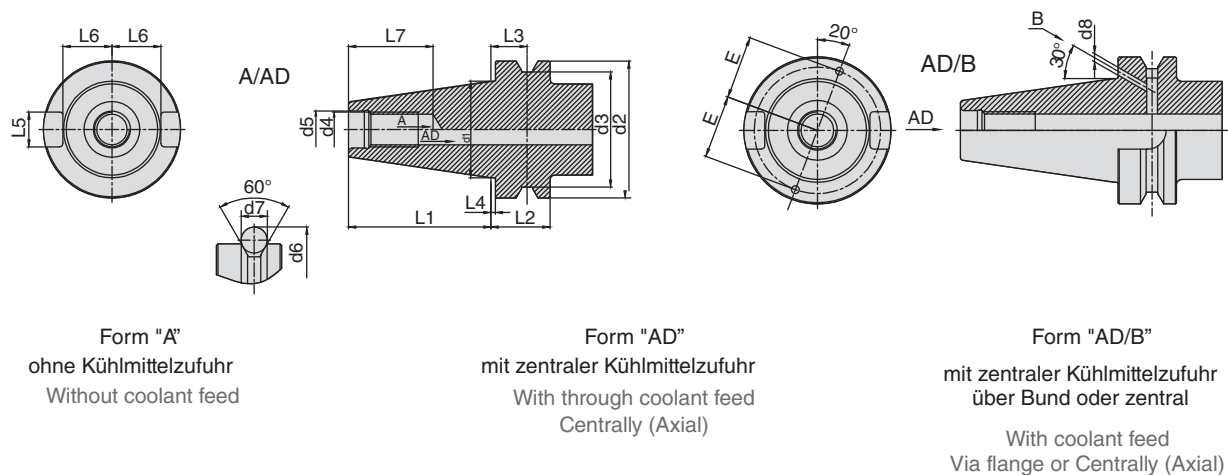

Size	d1	d2	d3	d4	d5	d6	d7	d8	L1	L2	L3	L4	L5	L6	L7	E
30	31,75	46	38	M12	12,5	56,27	8	–	48,40	22,0	13,60	2	16,1	16,3	35min	–
40	44,45	63	53	M16	17,0	75,68	10	4	65,40	27,1	16,60	2	16,1	22,5	42min	27
50	69,85	100	85	M24	25,0	119,00	15	6	101,80	38,2	23,20	3	25,7	35,3	55min	42

Form "AD" ⇌ Form "B"

Form "AD/B"

Typ 1 / Type 1

Form "AD"
(Auslieferungszustand)
(Delivery Condition)

Bild.1
Fig.1

Form "B"

Bild.2
Fig.2

Im Anlieferzustand sind die Aufnahmen für eine Kühlmittelzuführung nach Form AD (durch die Mitte, siehe Fig.1) ausgelegt. Zum Umstellen auf Form B die M5 Schraubenherausschrauben (siehe Fig.2) und mit Loctite sichern.

As delivered the adaptors are suitable for coolant supply according to form AD (centrally as shown in Fig.1). To switch to form B, unscrew the M5 screws to the top as shown in the Fig.2 and secure with Loctite.

Typ 2 / Type 2

Form "AD"
(Auslieferungszustand)
(Delivery Condition)

Bild.1
Fig.1

Form "B"

Bild.2
Fig.2

Im Anlieferzustand sind die Aufnahmen für eine Kühlmittelzuführung nach Form AD (durch die Mitte, siehe Fig.1) ausgelegt. Zum Umstellen auf Form B die M5 Schraubenherausschrauben (siehe Fig.2) und mit Loctite sichern

As delivered the adaptors are suitable for coolant supply according to form AD (centrally as shown in Fig.1). To switch to form B, unscrew the M5 screws to the top as shown in the Fig.2 and secure with Loctite

Übersicht Werkzeugschäfte HSK DIN 69893
 Overview tool shanks HSK DIN 69893

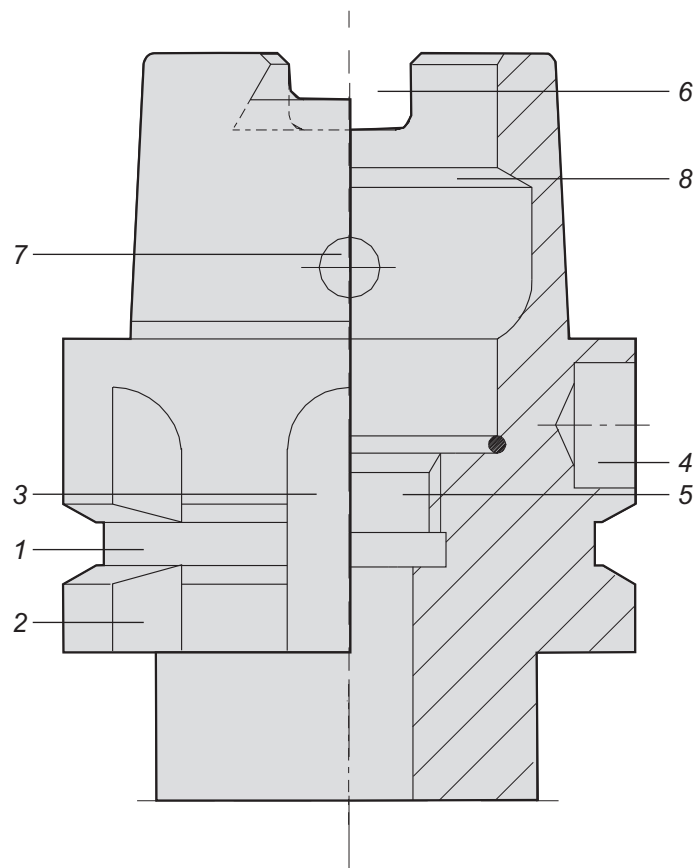

1 Greiferrille – umlaufende Nut

2 Deutsches Eck – sichelförmige Kerbe quer zur Greiferrille (dient zur Indexierung)

3 Mitnehmernut am Bund – zur Indexierung oder zur Aufnahme in einem Werkzeugmagazin oder Greifer. Bei HSK-B/D gleichzeitig zur formschlüssigen Drehmomentübertragung zur Spindel

4 Codierbohrung – zur Aufnahme eines Datenträgers (Codierchip) im Bund

5 Anschlussgewinde für Kühlmittelübergabeeinheit – zur Aufnahme des Kühlmittelrohrs

6 Mitnehmernut am Kegelschaft – formschlüssige Drehmomentübertragung zur Spindel

7 Radiale Zugriffsbohrung im Kegelschaft – zur Betätigung Manueller Spannsysteme

8 Spannschulter – Ringfläche, an der das Werkzeug eingezogen wird

1 Gripper groove – circular groove

2 Index notch – sickle-shaped notch across Gripper groove

3 Keyway on collar – index notch e.g. for tool magazines. Form closed torque transmission to spindle for HSK-B/D

4 Coding/identification – hole in collar for attachment of identification system (code chip)

5 Thread for coolant tube – for attachment of coolant tube

6 Keyway on taper shank – form closed torque transmission to spindle

7 Radial bore in taper shank – necessary for manual clamping systems

8 Clamping shoulder – circular chamfer for clamping

Übersicht Werkzeugschäfte HSK DIN 69893
 Overview tool shanks HSK DIN 69893

Form "A"

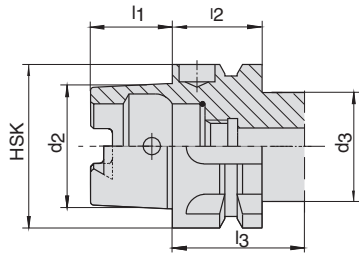

Der Hohlshaftkegel für automatischen Werkzeugwechsel mit Greif- und Indexiernut. Manuelle Betätigung durch Zugriffsbohrung im Kegel möglich. Das Drehmoment wird kraft- und formschlüssig übertragen

Form "B"

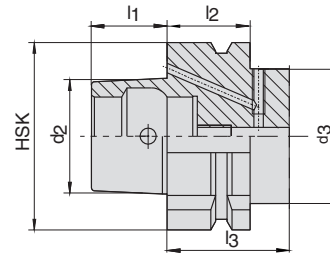

Hollow-shank taper for automatic tool changing with gripping and locating groove. Manual operation is possible through the access hole in the taper. Torque is transmitted both positively and non-positively.

Form "C"

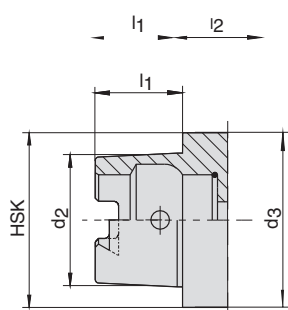

Der Hohlshaftkegel für manuellen Werkzeugwechsel. Betätigung durch Zugriffsbohrung im Kegel. Das Drehmoment wird kraft- und formschlüssig übertragen.

Form "D"

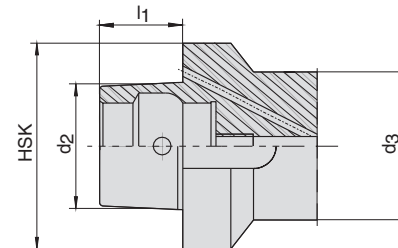

Hollow-shank taper for manual tool changing. Operation is possible through the access hole in the taper. Torque is transmitted both positively and non-positively.

Form "E"

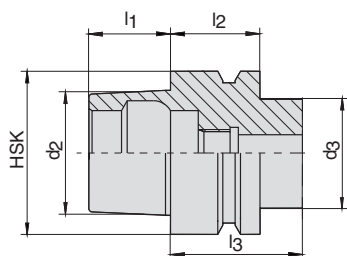

Der Hohlshaftkegel für automatischen Werkzeugwechsel (manuelle Betätigung durch Zugriffsbohrung im Kegel nicht möglich). Das Drehmoment wird kraftschlüssig übertragen.

Form "F"

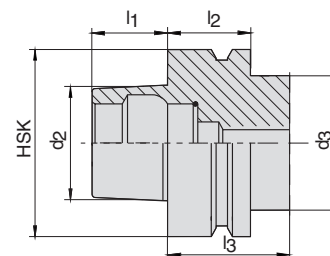

Hollow-shank taper for automatic tool changing (manual operation through access hole in taper not possible). Torque is transmitted non-positively.

HSK-A+C	d ₂	d ₃	l ₁	l ₂	l ₃	HSK-B+D	d ₂	d ₃	l ₁	l ₂	l ₃
32	24	26	16	20	35	40	24	34	16	20	35
40	30	34	20	20	35	50	30	42	20	26	42
50	38	42	25	26	42	63	38	53	25	26	42
63	48	53	32	26	42	80	48	67	32	26	42
80	60	67	40	26	42	100	60	85	40	29	45
100	75	85	50	29	45						

HSK-E	d ₂	d ₃	l ₁	l ₂	l ₃	HSK-F	d ₂	d ₃	l ₁	l ₂	l ₃
25	19	20	13	10	20	50	30	42	20	26	42
32	24	26	16	20	35	63	38	53	25	26	42
40	30	34	20	20	35	80	48	67	32	26	42
50	38	42	25	26	42						
63	48	53	32	26	42						

BT MAS 403
ISO7388-2

SK DIN 69871
ISO7388-1

HSK DIN 69893

Zubehör
Accessories

Ersatzteile
Spare Parts

Technische Spezifikationen
Technical Details

Hochleistungsfräserspannfutter - Eigenschaften und Vorteile
 Hi-Power Milling Chuck - Features & Advantages

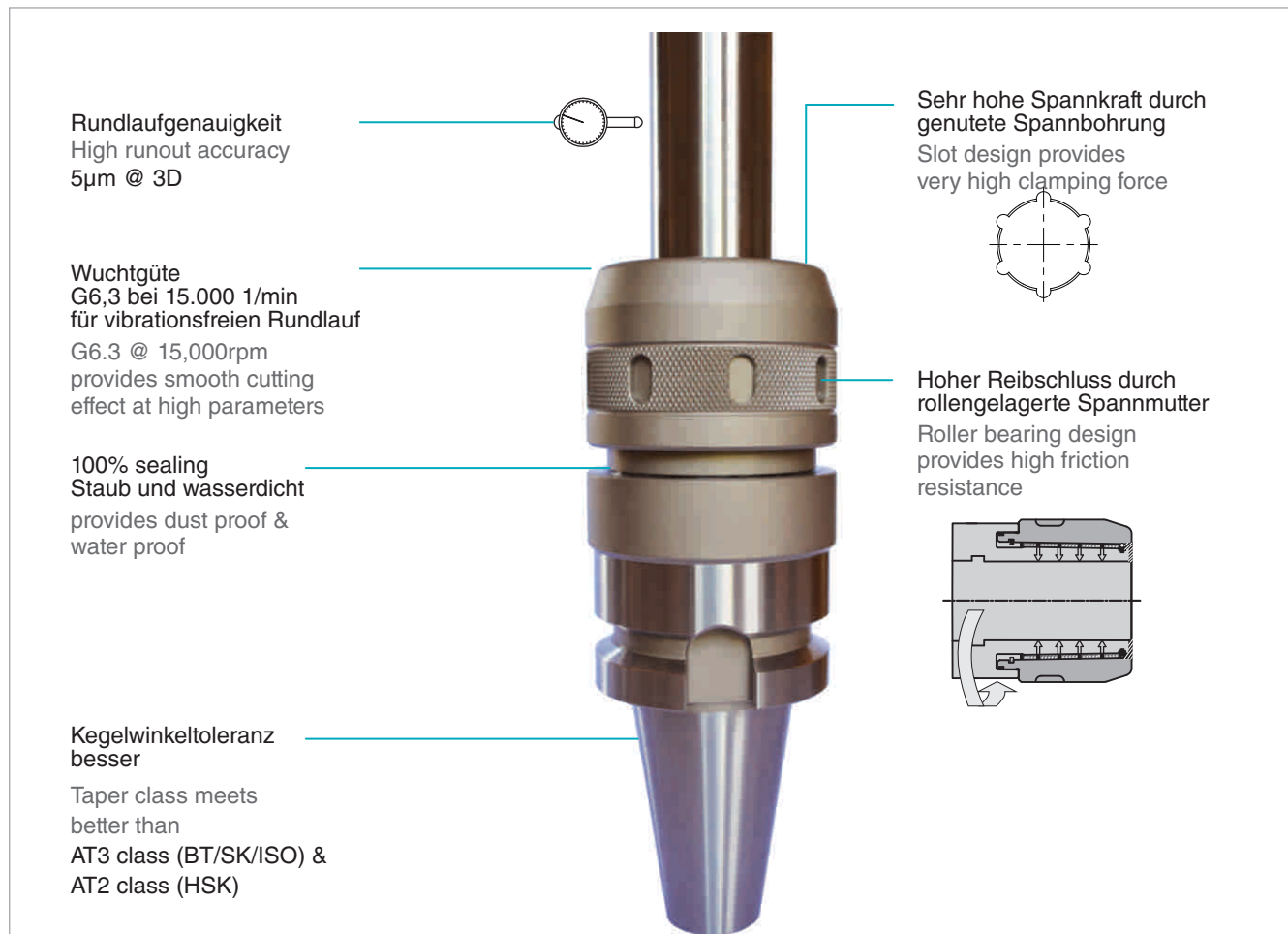

Zusätze und Vorteile

- Sehr hohe Spannkraft fuehrt zu verbesserter Produktivitaet und Standzeit
- Geringe Reibung durch Konstruktion mit Rollenlager
- Hohe Rundlaufgenauigkeit von 5µm bei 3D
- Ausgezeichnete Oberflächenqualität da weniger Vibrationen
- Mit Antikorrosionsbeschichtung geschützt
- Ein neu entworfener Dichtmechanismus der Mutter verhindert Verunreinigung durch Staub und Kühlflüssigkeit, dadurch wird die Standzeit des Werkzeuges erhöht

Features and Advantages

- Very high clamping force leads to increased productivity and tool life
- Roller bearing design provides high friction resistance
- High run out accuracy 5 micron @ 3D. Less wear on cutting edge leads to significant increase in tool life
- Excellent finish on machined surface due to less vibration
- Protected with anti-corrosive coating
- Perfect seal mechanism of clamping nut, prevents dust and coolant entry. Thereby, extending life of the holder

Hi-Power Milling Chuck - Anzugsmomente und Spannkräfte / Torque chart

(für Größe) (for Size)	Anzugsmoment (Nm) Tightening Torque (Nm)	Spannkraft (Nm) Clamping Force (Nm)	Schaft Ø (mm) Shank Ø (mm)
WHPMC 20	30	400 - 500	20h6
WHPMC 25	70	550 - 700	25h6
WHPMC 32	80	700 - 900	32h6

Slim Hi-Power Milling Chuck - Anzugsmomente und Spannkräfte / Torque chart

(für Größe) (for Size)	Anzugsmoment (Nm) Tightening Torque (Nm)	Spannkraft (Nm) Clamping Force (Nm)	Schaft Ø (mm) Shank Ø (mm)
WHPMC S06	20 - 30	30 - 45	6h6
WHPMC S08	20 - 30	45 - 60	8h6
WHPMC S10	20 - 30	60 - 80	10h6
WHPMC S12	20 - 30	100 - 150	12h6
WHPMC S16	20 - 30	250 - 300	16h6
WHPMC S20	20 - 30	300 - 350	20h6

Montage / Assembly

Stellen Sie sicher, dass bei der direkten Montage des Werkzeugs die Stellschraube im Spannfutter eingebaut ist, um den korrekten Sitz des Schneidwerkzeugs zu gewährleisten
Please ensure that the adjusting screw is located before direct mounting of tool, as this ensures the correct seating of the cutting tool



Zum Montieren der Spannzange sollte die Stellschraube aus dem Spannfutter entfernt werden
Please remove the adjusting screw before mounting the collet

Die Längsrillen der Spannzange und des Fräsers sollten in versetzter Winkellage montiert werden
Please ensure that the straight collet and milling chuck slot do not coincide, if it coincides then the clamping torque will not be consistent

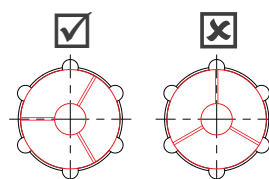

Einspannen-Ausspannen / Clamping-UnClamping

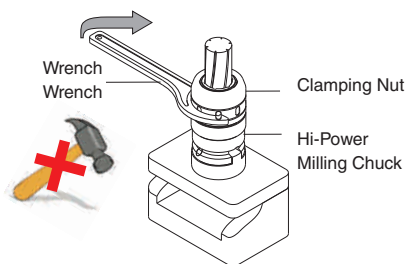

Die Spannmutter wird mit dem mitgelieferten Schlüssel gemäß Drehmomenttabelle angezogen. Verwenden Sie keinen Hammer, kein Rohr oder Ähnliches, um das Drehmoment zu erhöhen. Eine Erhöhung des Drehmomentes ergibt keine Erhöhung der Spannkraft, sondern beschädigt das Spannfutter. Das Werkzeug muss vertikal in den Halter montiert werden (siehe Abb.).
Kombinieren Sie nicht verschiedene Verlängerungen.
Bitte nicht auf der Maschine ein-/oder ausspannen.

Please use wrench provided to clamp the cutting tool into the chuck to the specified clamping torque. Do not use a hammer, pipe, or any other device to exert added torque on the wrench. Excessive torque will damage the clamping chuck. The tool should be mounted in the holder in the vertical position as shown in fig.
Do not combine several extensions.
Do not clamp or unclamp on the machine

Das Hi-Power Fräserspannfutter sollte nie ohne Schneidwerkzeug gespannt werden. Die einwirkenden Spannkraften verursachen eine permanente Verformung der Innenbohrung
The Hi-power milling chuck should never be tightened without a cutting tool inside the bore. High gripping forces will cause permanent ID deformation

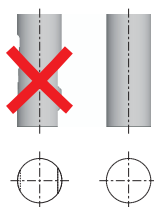
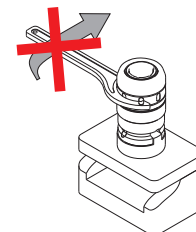

Die beste Leistung des Hi-Power Fräserspannfutters wird erreicht, wenn das Schneidwerkzeug rund ist, ohne Weldon- oder Whistle Notch-Flächen. Schneidwerkzeuge mit Weldon- oder Whistle Notch-Flächen können gespannt werden, haben jedoch einen negativen Einfluß auf Rundlauf und Wuchtgüte

Best performance from the Hi-power milling chuck is attained when the cutting tool shank is round, without flats and within h6 tolerance. Cutting tools with small flats may be held, but run-out and balancing grade will not be consistent

Wartung / Maintenance :

Wenn das Hi-Power Fräserspannfutter über einen längeren Zeitraum nicht benutzt wird, lösen Sie die Mutter, säubern und trocknen Sie diese und verwenden Sie ein Rostschutzmittel; wasserlösliche Kühlmittel, Rost, Ölfilme, Staub usw., die auf dem Spannfutter bleiben, können verkleben und zu Betriebsausfällen führen, daher sollten diese ebenfalls gesäubert, getrocknet und mit einem Rostschutzmittel behandelt werden

If the Hi-power milling chucks are not used over a prolonged period of time, loosen the nut, wipe clean, dry and apply rust inhibitor. Water-soluble coolant, rust, oil film, dust, etc. remaining on the Hi-power milling chucks may stick and result in operation failure, so please wipe them clean and dry, and apply rust inhibitor

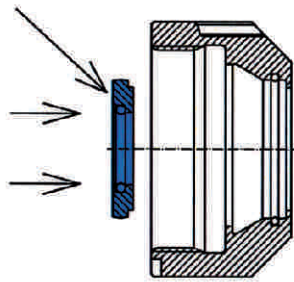

Einbau

Beim Einsetzen der Dichtscheibe in die Spannmutter muss die Beschriftung der Dichtscheibe von hinten her lesbar sein.

Assembling

Insert the small diameter of the disk into the center of the coolant nut and apply even pressure until the disk is properly seated into the nut.

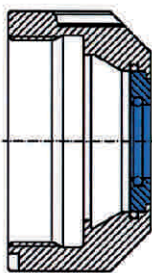

Dichtscheibe in die Spannmutter einlegen und nach vorne drücken, bis ein deutliches „Klicken“ zu hören ist. Jetzt ist die Dichtscheibe richtig in die Spannmutter eingesetzt. Die richtig montierte Dichtscheibe ist vorne mit der Spannmutter bündig.

The disk must be flush with the outside of the nut and the marking on the disk must be seen inside the nut.

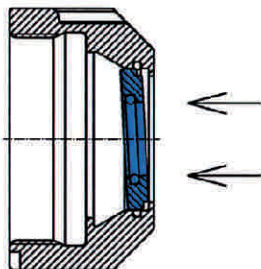

Ausbau

Um die Dichtscheibe herauszunehmen, von der Außenseite auf die Dichtscheibe drücken, bis sie herausspringt.

Removing

To remove the disk, simply press on the outside of the disk evenly until it snaps out.

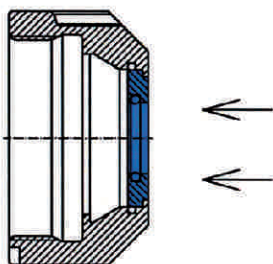

! Unbedingt Werkzeug von vorne einführen, sonst wird der O-Ring in der Dichtscheibe beschädigt.

! Insert tool from the front. O-ring might be destroyed if cutting tool is inserted from the back.

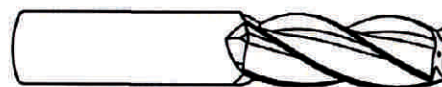

! Beim Einführen vom Werkzeug darauf achten, dass die Dichtscheibe nicht zurück geschoben wird.

! Take care when inserting the tool that you do not push back the sealing disc.

Weitere BILZ Produktkataloge Further BILZ product catalogues

Fordern Sie heute noch kostenlos per E-Mail oder unter info@bilz.de unsere Kataloge an.
Order our catalogues free of charge by email to info@bilz.de today!

Unser **TapGrip** Spannsystemekatalog
Our **TapGrip** Clamping Systems Catalogue
Kat. Nr.: 5073262

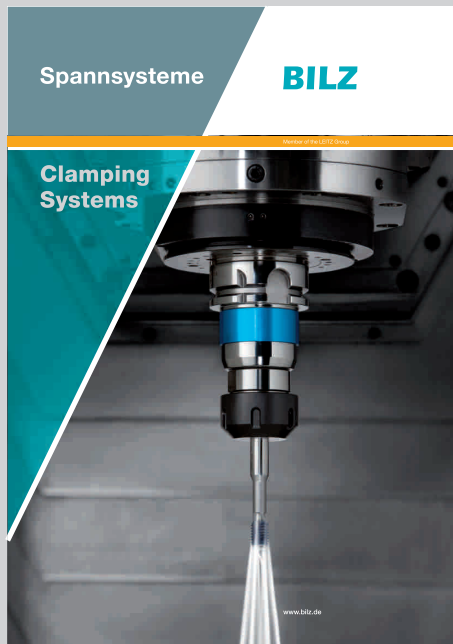

Unser **ThermoGrip** Schrumpffutterkatalog
Our **ThermoGrip** Shrink Chucks Catalogue
Kat. Nr.: 5053454



Unser **ThermoGrip** Schrumpferätecatalog
Our **ThermoGrip** Shrink Machine Catalogue
Kat. Nr.: 5053455

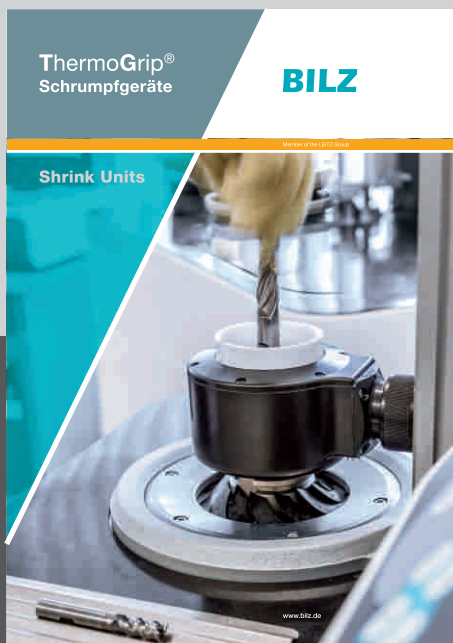

Unser **BTC** Gerätecatalog
Our **BTC** Machine Catalogue
Kat. BTC



BILZ

Member of the LEITZ Group

**BILZ WERKZEUGFABRIK
GmbH & Co. KG**
Vogelsangstr. 8
73760 Ostfildern
Deutschland / Germany
Telefon +49 711 348 01 - 0
Telefax +49 711 348 12 56
info@bilz.de
www.bilz.de

OTTO BILZ (INDIA) PVT. LTD.
No.5A-5B/6A, KIADB Industrial Area
Doddaballapur - 561203
Bengaluru District
Karnataka, India
Tel +91 080 22638700
Fax +91 080 22638702
sales@bilzindia.com
www.bilzindia.com



*Produktions- und Vertriebsstandorte der LEITZ-Group
Production and sales locations of the LEITZ Group*

- Bilz
- Boehlerit
- Leitz